

Aufbauanleitung

Sweet II 200

Konditoreitheke

[Art. 4597250051] / [Art. 4597250201]



Descrizione del mobile - Cabinet description – Description du meuble - Beschreibung der Bedientheke - Descripción de la cámara – Описание прилавка

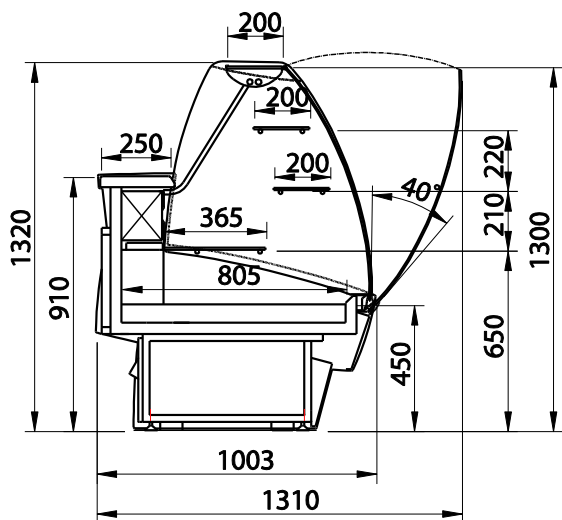

SWEET 2

Fig. 1

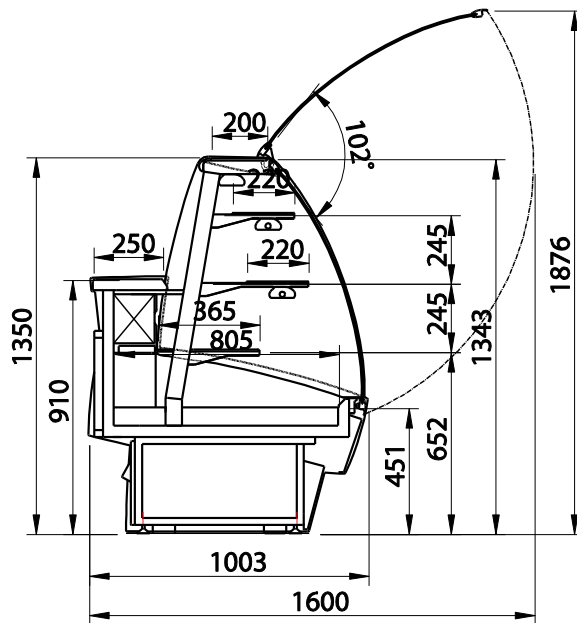

SWEET 2 LX

Fig. 2

Trasporto del mobile – Cabinet handling – Transport du meuble - Transport des Kühlmöbels - Desplazamiento de la cámara – Перевозка прилавка

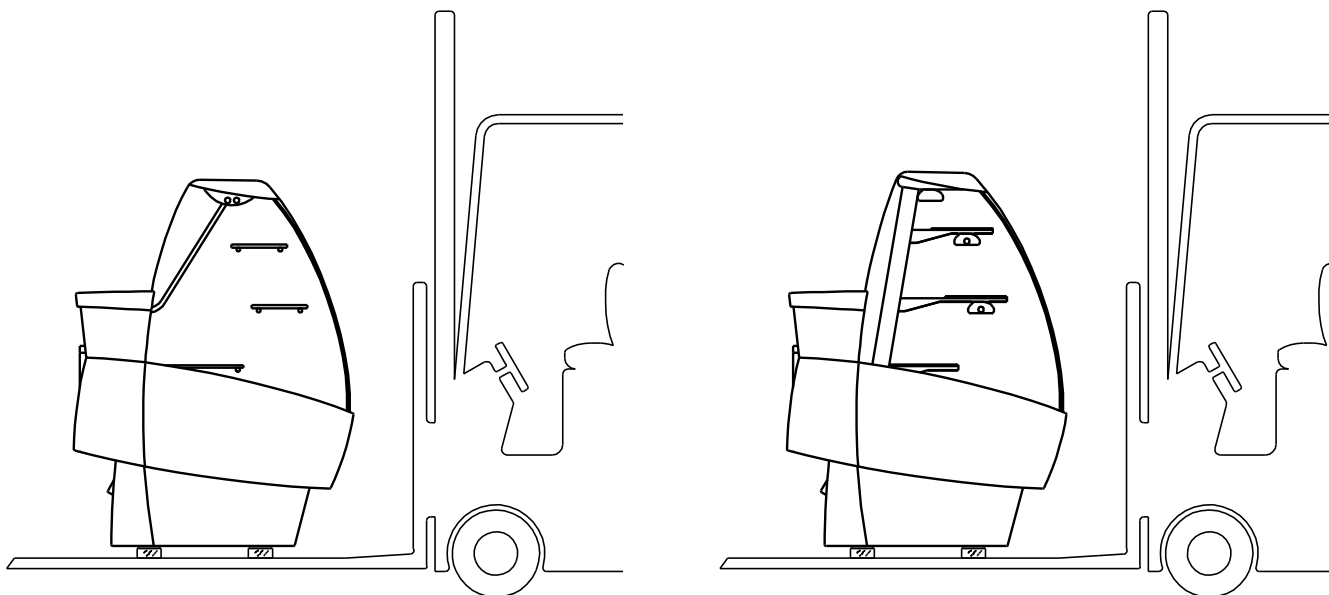

Fig. 3

- PUNTO D'INNESTO FORCHE PER LA MOVIMENTAZIONE
- LIFTING POINT
- POINTS DE SOULEVEMENT
- ANSATZPUNKTE FÜR HUBKARREN
- PONTOS PARA EL LEVANTAMIENTO
- ТОЧКА ПОДЪЕМА АВТОПОГРУЗЧИКОМ

	SWEET 2					SWEET 2 LX				
	100	200	300	AI45°	AE45°	100	200	300	AI45°	AE45°
Lunghezza / Length (mm)	1018	1955	2893	-	-	1018	1955	2893	-	-
Peso / Weight (kg)	140	250	360	110	110	150	260	375	130	130

Installazione e condizioni ambientali - Installarono and environmental conditions - Installation et conditions ambiantes - Inbetriebnahme und Einsatzbedingungen - Instalación y condiciones ambientales - Установка и условия окружающей среды

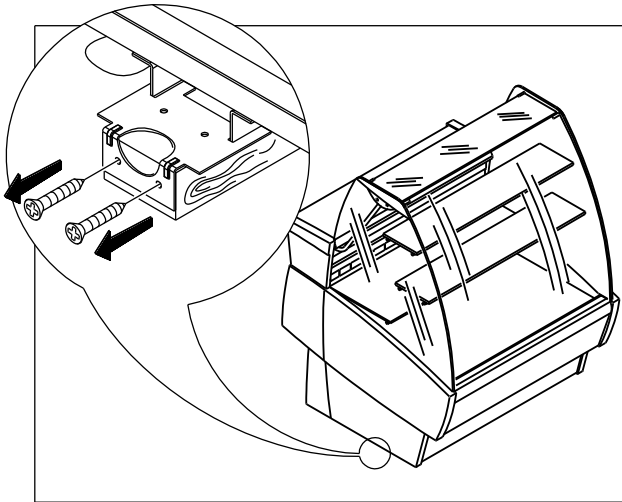

Fig. 4A

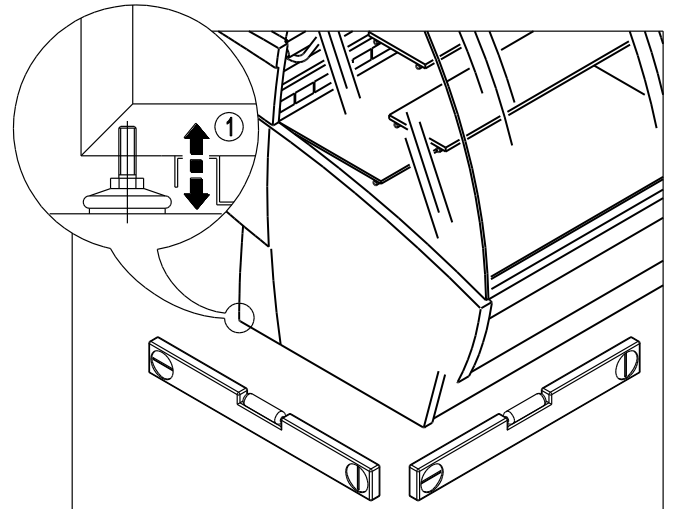

Fig. 4B

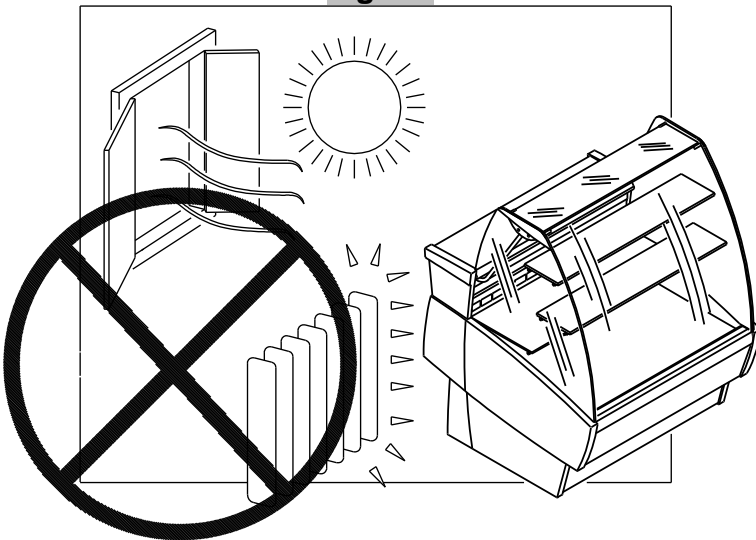

Fig. 5



Fig. 6

Collegamento elettrico e dati tecnici - Cabling electrical and technical data - Branchement électrique et données techniques - Elektrischer Anschluss und technische daten- Conexión eléctrica y datos técnico - Электрическое соединение и технические данные

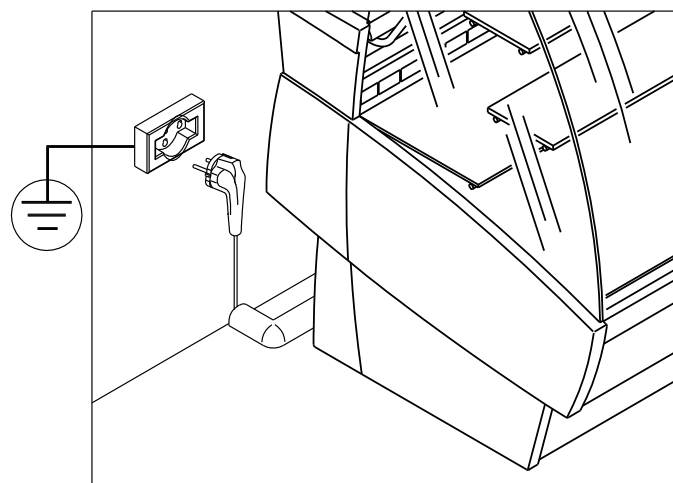

Fig. 7

SWEET 2	SWEET 2 G.I.					SWEET 2 G.E.				
	100	200	300	AI45°	AE45°	100	200	300	AI45°	AE45°
Potenza assorbita (W) <i>Absorbed Power (W)</i>	397	503	670	393	324	18	58	54	14	14
Potenza assorbita (W) in sbrinamento elettr. (optional) <i>Absorbed Power (W)</i> <i>in electric defrost (optional)</i>	168	258	314	164	114	168	258	314	164	114
Temperatura d'esercizio <i>Working temperature</i>	+4°C/+8°C									

SWEET 2 LX	SWEET 2 LX G.I.					SWEET 2 LX G.E.				
	100	200	300	AI45°	AE45°	100	200	300	AI45°	AE45°
Potenza assorbita (W) <i>Absorbed Power (W)</i>	433	677	832	424	355	54	174	216	45	45
Potenza assorbita (W) in sbrinamento elettr. (optional) <i>Absorbed Power (W)</i> <i>in electric defrost (optional)</i>	204	374	466	195	145	204	374	466	195	145
Temperatura d'esercizio <i>Working temperature</i>	+4°C/+8°C									

Tab. 1

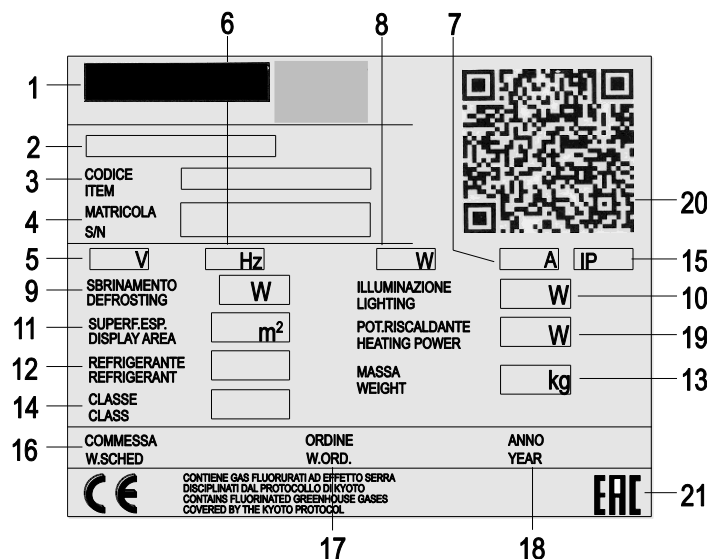

Fig. 8

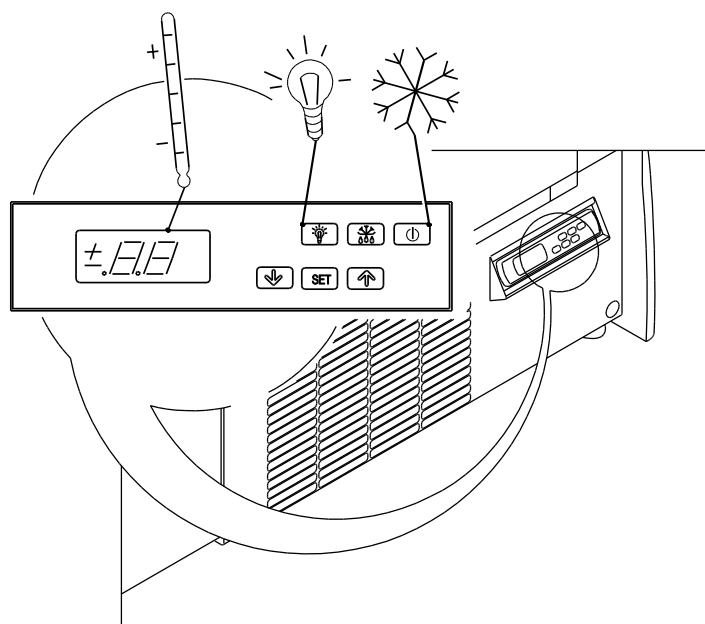

Fig. 9

SWEET 2

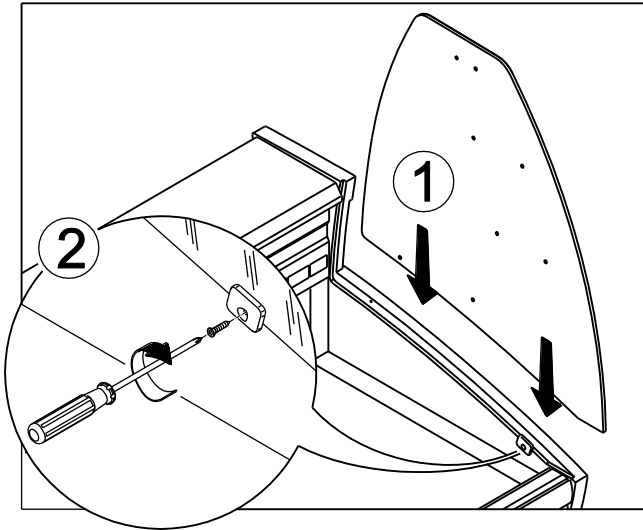

Fig. 10

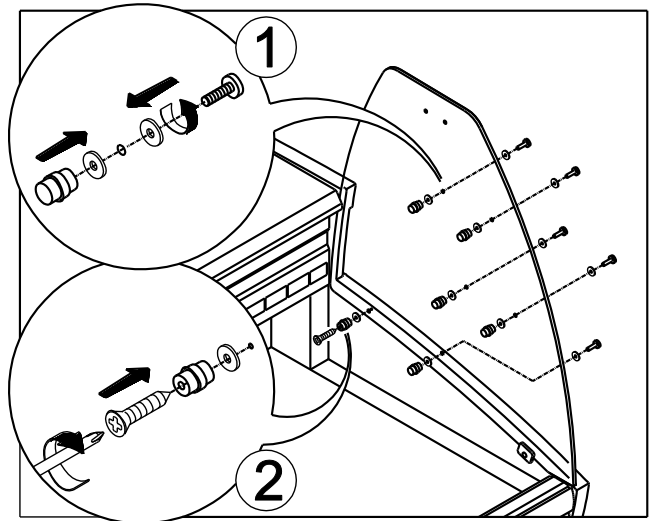

Fig. 11

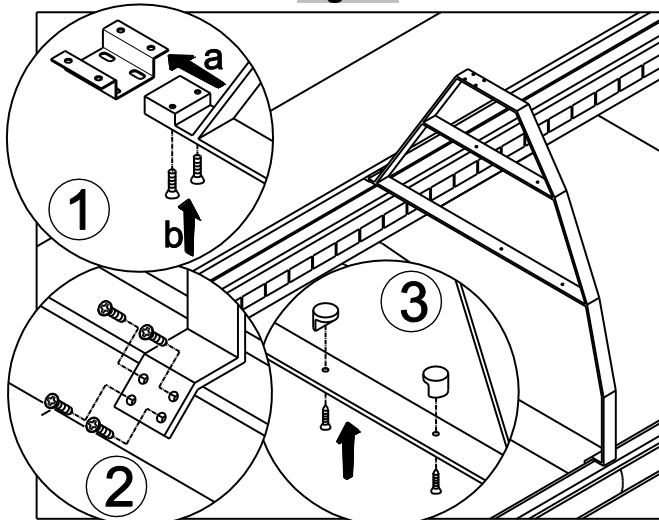

Fig. 12

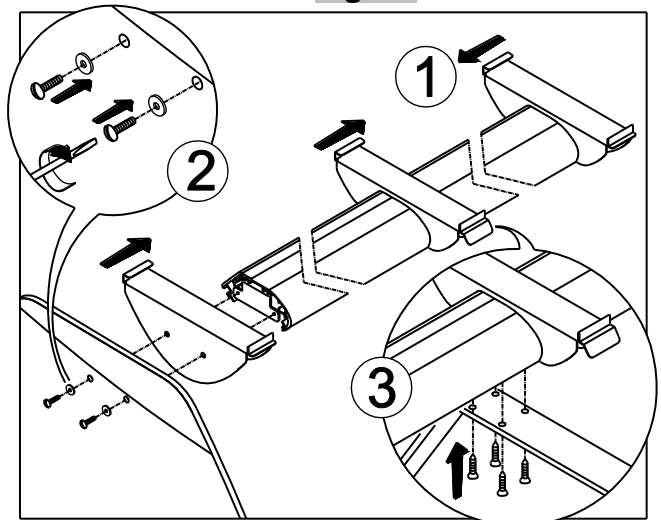

Fig. 13

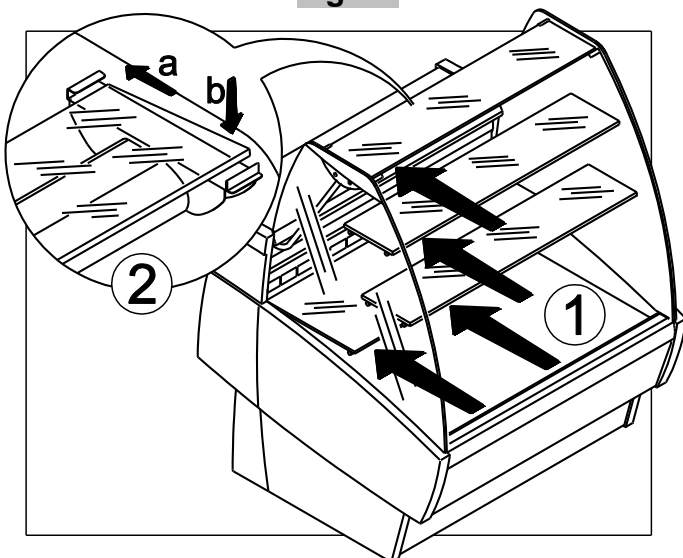

Fig. 14

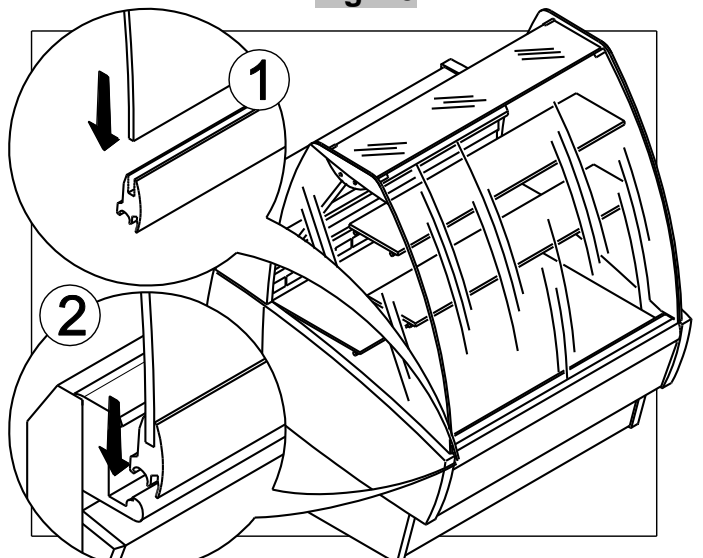

Fig. 15

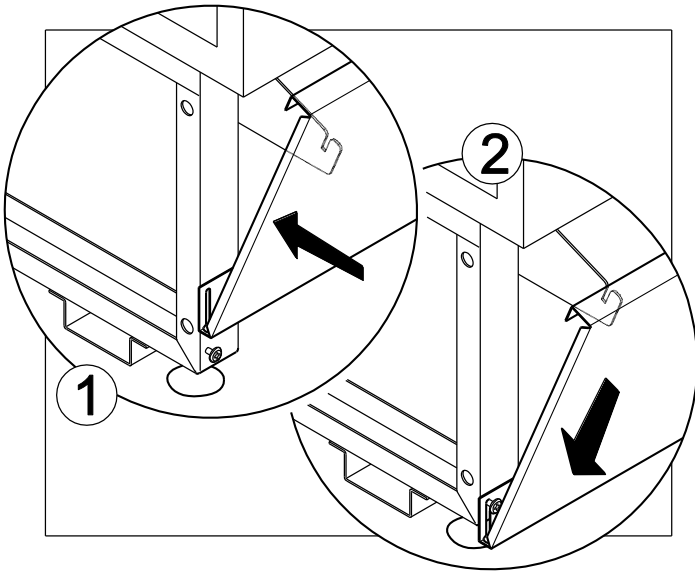

Fig. 16A

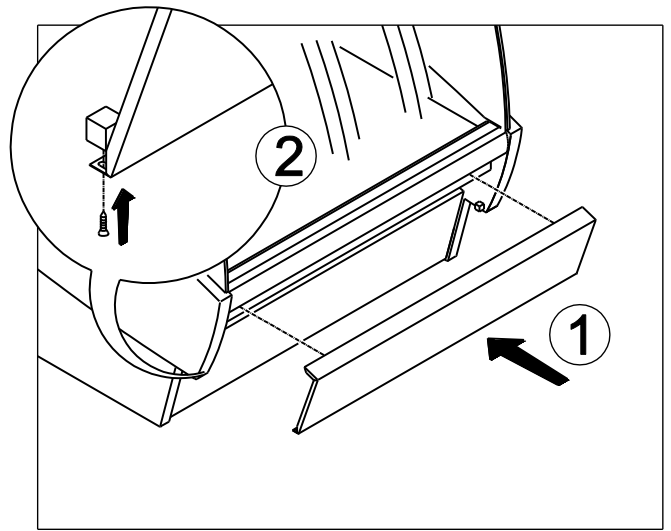

Fig. 16B

SWEET 2 LX

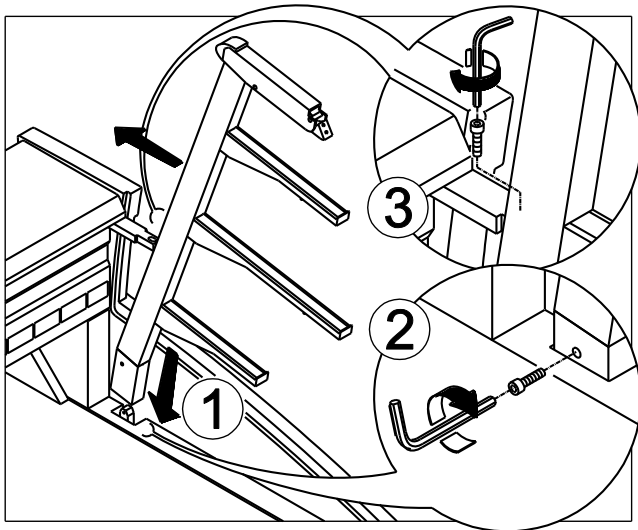

Fig. 17

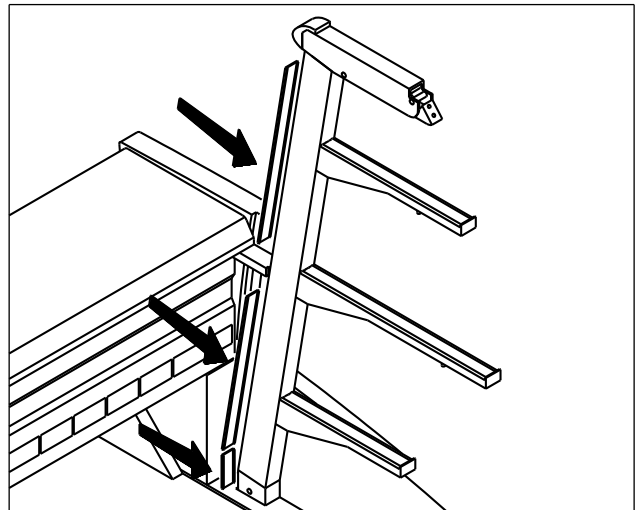

Fig. 18

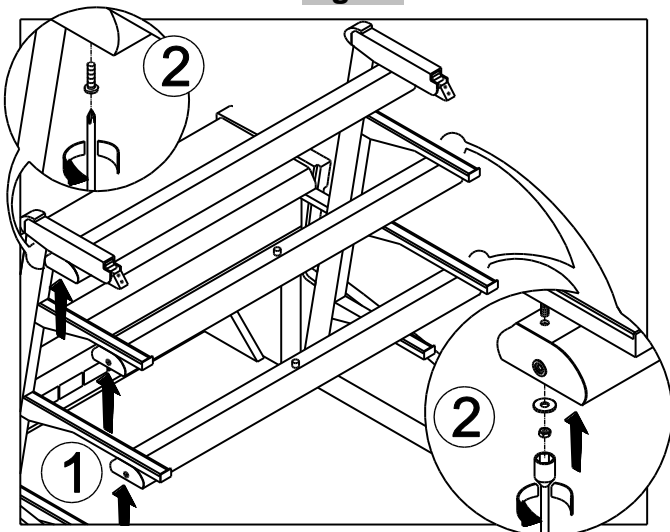

Fig. 19

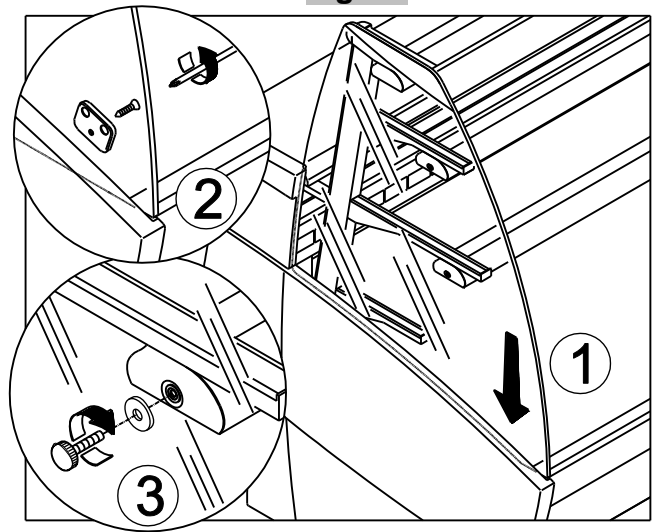

Fig. 20

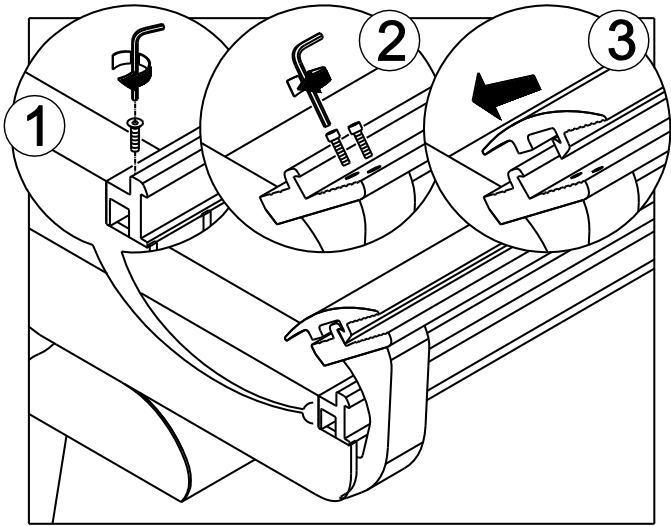

Fig. 21

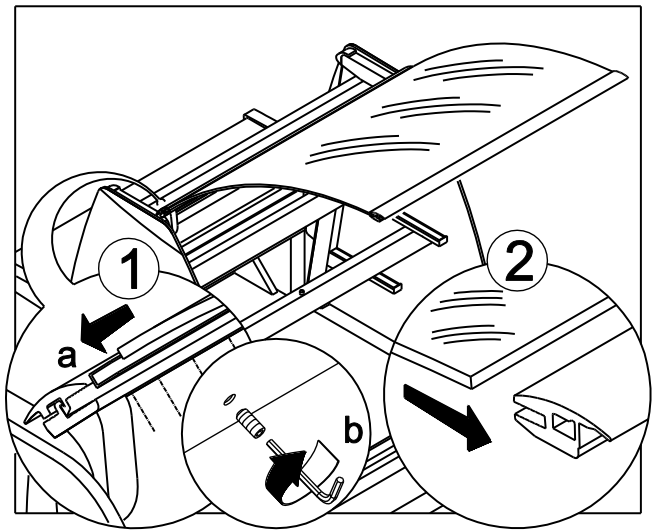

Fig. 22

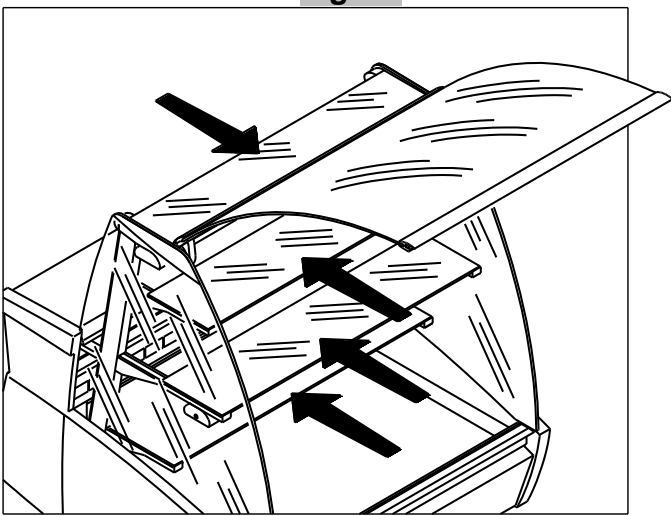

Fig. 23

**Manutenzione ordinaria – Routine maintenance – Entretien de routine - Ordentliche Wartung-
Mantenimiento de rutina – Техническое обслуживание прилавка**

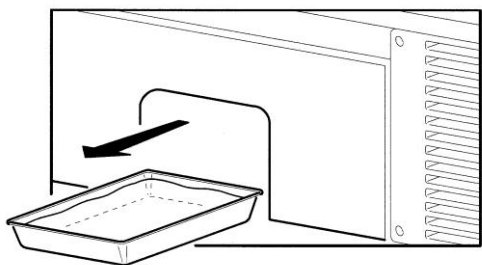

Fig. 24

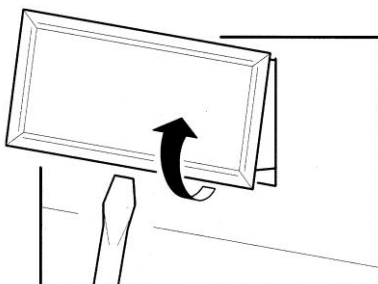

Fig. 25A

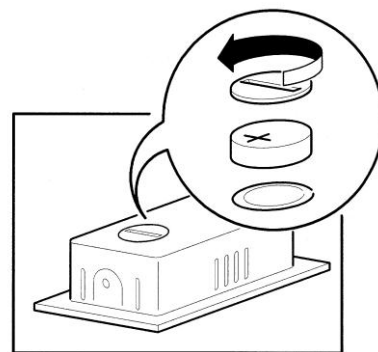

Fig. 25B

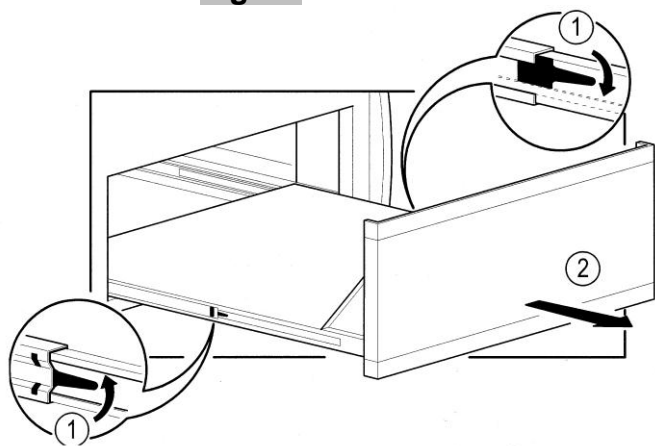

Fig. 26A

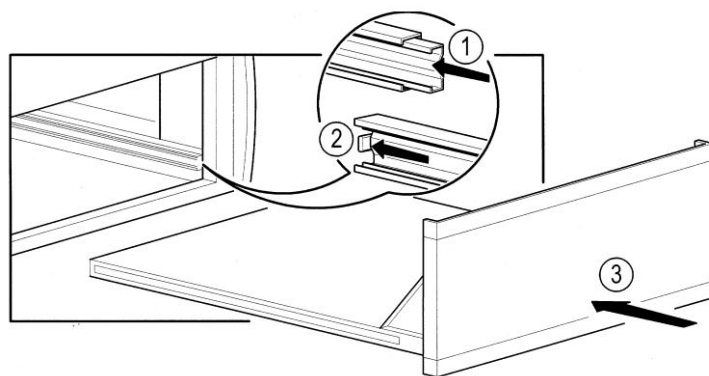

Fig. 26B

**Manutenzione straordinaria – Special maintenance – Entretien extraordinaire –
Außerordentliche Wartung - Mantenimiento extraordinario – Техническое обслуживание
прилавка**

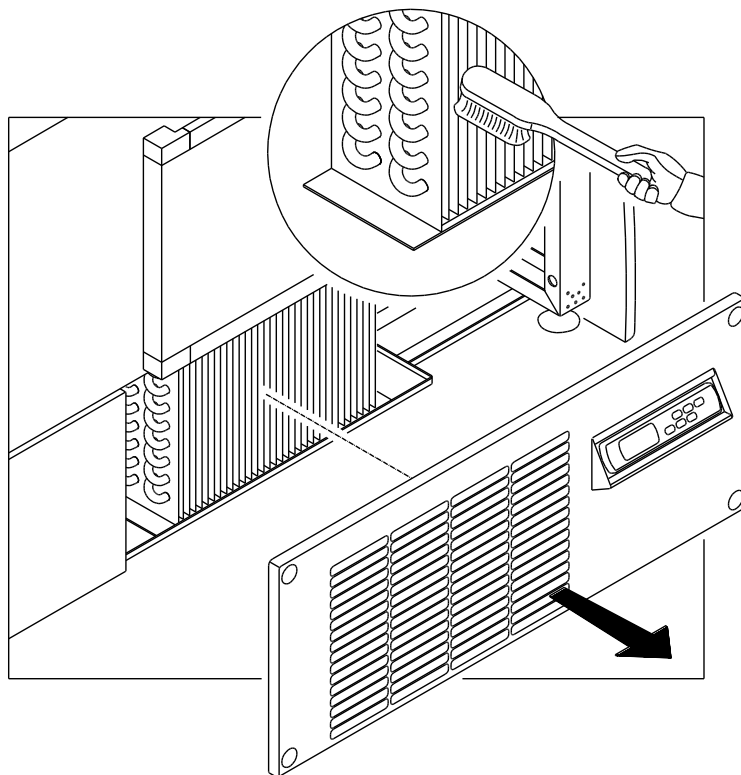

Fig. 27

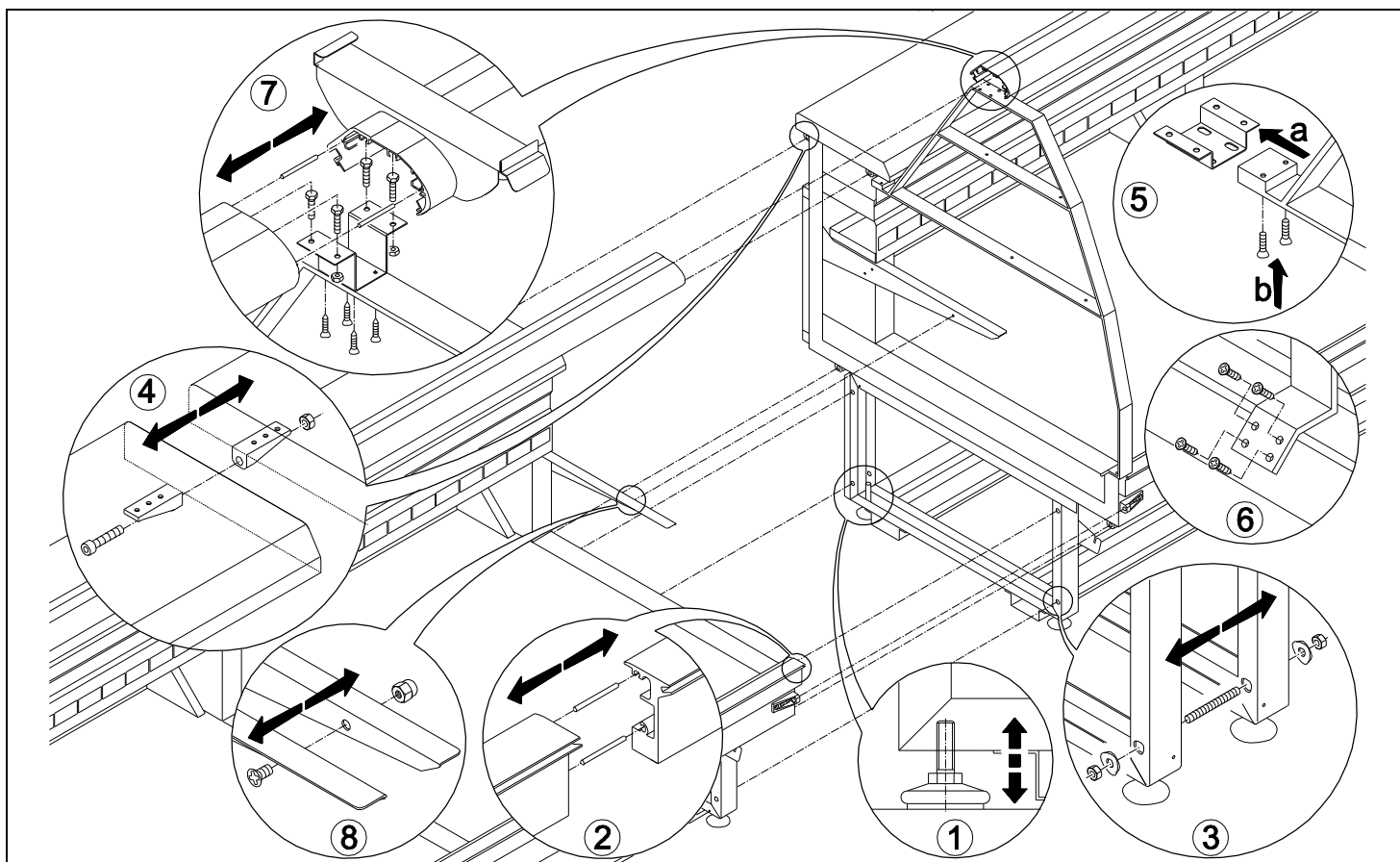

Fig. 28 Sweet 2

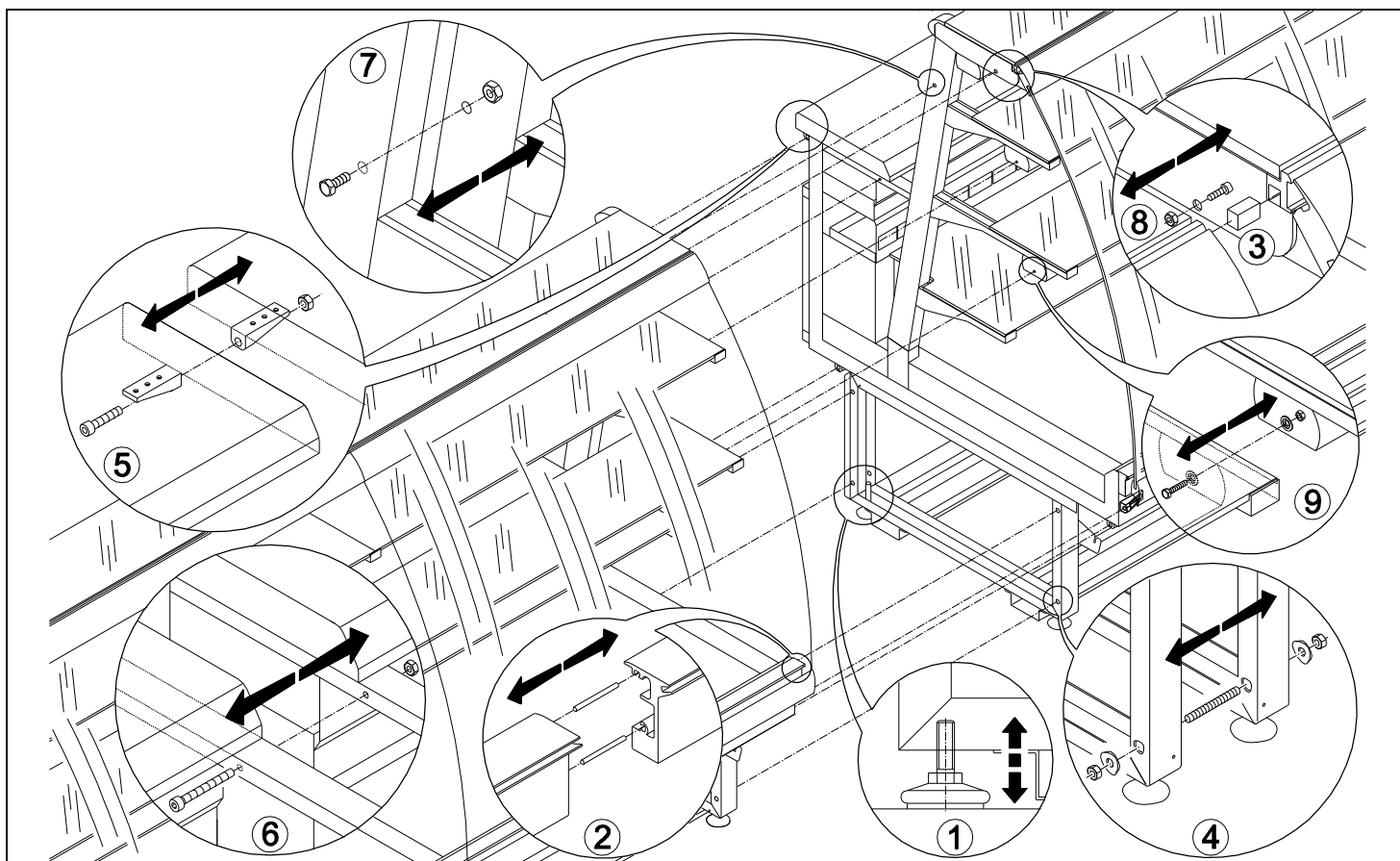

Fig. 29 Sweet 2 LX

