

Sweet 2 L100

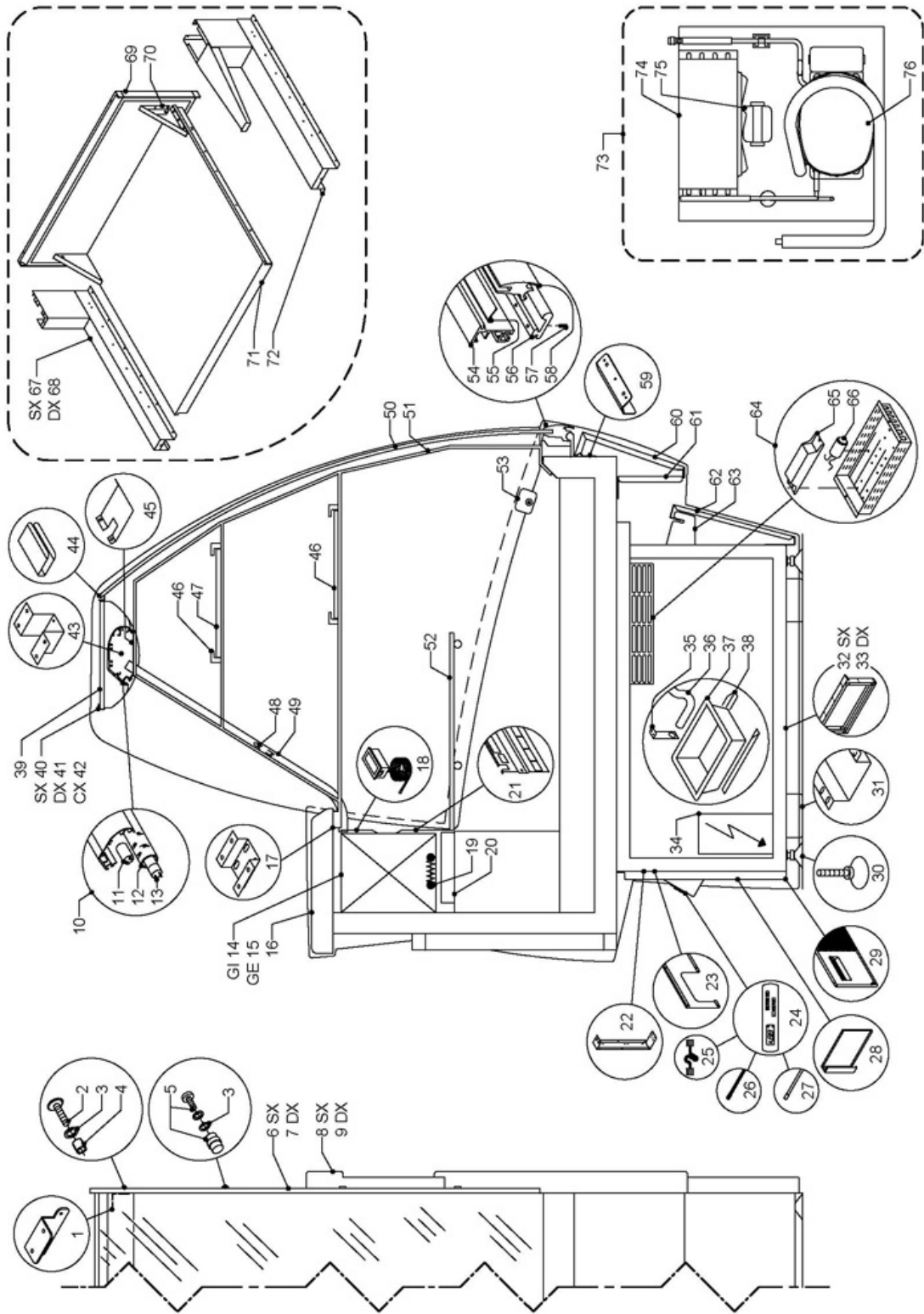

N°	Codice	Descrizione
1	725702	STIRRUP ZNT CANOPY HOLDER SWEET2/ZARA
2	038000	SCREW POLIERS TC- M4X15 INOX
3	039348	PLASTIC WASHER 6X18 FOR SIDE GLASS
4	379328	PVC CAP FOR GLASS
5	040097	SUPPORT FOR INTERM.GLASS SWEET
6	725505	SPALL.TERMOF.SX RAL9006 SWEET2
7	725506	SPALL.TERMOF.DX RAL9006 SWEET2
8	725511	CRISTALLO LAT.SX SWEET2 STD
9	725512	CRISTALLO LAT.DX SWEET2 STD
10	725523	ASS.PLAF.CABL.SWEET2 STD 100
11	048940	STARTER ST 111 OSRAM
12	046632	COVER LAMP PROFILE IM-29 L= 585
13	046762	LAMP.FL.L.18W/840 (D.26X590)
14	041446	EVAPORATOR WITH SUCTION PIPE SWEETL100
15	041450	COM.EV.SWEET ST.GE.100
16	725519	WORKING SHELF MM 250 SWEET2 937
18	042721	DIGITAL THERMOMETER -40/+70 24W
19	046568	DOUBLE DEFROST HEATER D6 L93,7
20	650513	WATER TRAY L=100
21	650542	GRID FOR EVAPOR.COVER SWEET L=100
23	650623	COVER BACK PLATE SWEET L=100
24	042760	INTERFACE FOR ELECTRONIC CONTROL BOARD
25	042727	CAVO CONNES.EVCO1256800044 MT1
26	04510552	PROBE FOR TELETHERM.NTCIP68 L=4000BLACK
27	04510550	PROBE FOR TELETHERM.NTCIP68 L=4000GREEN
28	725584	TAMP.LAT.CONDENSATORE SWEET2
29	681296	COVER GRID CONDENSER MARTE/MAJOR
30	37559000	ADJUSTING FRONT FOOT M10X65 D35 RAL9006
31	666040	FRAME CROSS MEMBER SWEET/VEGA L937
32	650549	FRAME LEFT SWEET
33	601000	FRAME ELIOS/ASTRA/MINOR
34	681003	WIRED POWER MODULE EVG003
35	552218	BRACKET FOR PIPE H20 COND.
36	00170612	GREEN PLASTIC PIPE D20-27
37	045651	WATER PLASTIC TRAY CM.10X36X9H
38	621062	"C" PROFILE TO SUPPORT WATER TRAY
39	725537	CRIST.RENDIR.SWEET2 L100
40	725513	SUPP.SX RENDIR/PLAF.SWEET2 STD
41	725514	SUPP.DX RENDIR/PLAF.SWEET2 STD
45	681458	PROTECTION FOR LIGHTING CANOPY GIOVE
47	725685	CRIST.INTERM.SWEET2 STD L100
48	650972	WIRING KIT SUPERSTRUC.SWEET 100/200
49	725522	TUBO X PASS.CAVI PLAF.SWEET2
50	725500	CRISTALLO CURVO SWEET2 L=100
52	650507	LOWER GLASS SHELF SWEET L=100
53	049218	PLASTIC CLAMP FOR SIDE GLASS
54	725827	PR.FRONT.ALL.725816 SWEET2 100
55	725571	PROF.GUARNIZIONE FRONT.SWEET2
56	725830	PR.RIBAL.ALL.725817 SWEET2 100
57	038546	GRANO PIANO UNI5923 M4X10 ZNT.
58	725831	PR.MANIG.ALL.725818 SWEET2 100
59	725517	SQUADRETTA SUPERIOR.DEC.SWEET2
60	725597	RED RAL3020 DEC.TRIMS SWEET2 100
62	725585	FRONT PLINTH RAL9006 SWEET2 L100
63	725516	LAM.SUPPORTO ZOCCOLO SWEET2
64	692223	PAN.REAT.MINI 1X20 220/50HZ
65	046948	BALLAST 20W 220/50HZ
66	045600	CAPACITOR MF4
67	650616	BOTTOM SHELF L WITH BRACKET SWEET
68	650617	BOTTOM SHELF R WITH BRACKET SWEET
69	650628	PORTELLO CASSETTONE/A SWEET
70	650669	HOLDER FOR SWEET DRAWER
71	650698	S/S SLIDING SHELF SWEET DRAWER
73	098520	COND.UNIT R404A B6165GK ASTRA/GIOVE 125
74	041897	CONDENSER
75	043041	FAN MOTOR FOR COMPRESSOR 10/38 W
76	045350	COMPRESSOR R404A ASPERA B6165GK