

Aufbauanleitung

COOL-LINE-Minitiefkühlzelle Z 2000 TK

[Artikel-Nr.: 46710714001-0-0-0]



**Assembly Diagram
Schème de Montage
Montageanleitung
Montage Overzicht
Esquema de Montagem
Schema di Montaggio
Diagrama del Ensamblaje**

INDEX | INDICE | INDEX | INDEX | ÍNDICE | INDICE | ÍNDICE

1	PREPARATION PRÉPARATION VORBEREITUNG VOORBEREIDING PREPARAÇÃO PREPARAZIONE PREPARACIÓN 	3
2	CAMLOCK FASTENING SERRAGE DES CROCHETS ANSCHRAUBEN DER HACKEN BEVESTIGEN VAN DE KLEMHAKEN APERTO DOS FECHOS AGGANCIAMENTO DEI FASTENERS APRIETE DE LOS GANCHOS	4
3	ASSEMBLY SEQUENCE SÉQUENCE DE MONTAGE MONTAGESEQUENZ VOLGORDE VAN DE MONTAGE SEQUÊNCIA DE MONTAGEM SEQUENZA DI MONTAGGIO SECUENCIA DE MONTAJE	5
4	DOOR REVERSIBILITY AND ADJUSTMENTS RÉVERSIBILITÉ DE LA PORTE ET RÉGLAGES UMKEHRBARE TÜR UND TÜREINSTELLUNG OMKEERBAARHEID VAN DE DEUR EN REGULINGEN REVERSIBILIDADE DA PORTA E AFINAÇÕES REVERSIBILITÀ DELLA PORTA ED AFFINAZIONI REVERSIBILIDAD DE LA PUERTA Y REGLAJES	9
4.1	Door reversibility Réversibilité de La Porte Umkehrbare Tür Omkeerbaarheid van de deur Reversibilidade da porta Reversibilità della porta Reversibilidad de la puerta	9
4.2	Door lock adjustment Réglage de la serrure de la porte Einstellung des Türschlosses Regeling van het deurslot Ajustagem do fecho da porta Affinazione della serratura della porta Ajuste de la cerradura de la puerta	10
4.3	Door hinges adjustment Réglage des charnières de la porte Türscharnieren anzupassen Regeling van de deurscharnieren Ajustagem das dobradiças da porta Modificare le cerniere della porta Ajustar las bisagras de la puerta	11

1 PREPARATION | PRÉPARATION | VORBEREITUNG | VOORBEREIDING | PREPARAÇÃO | PREPARAZIONE | PREPARACIÓN

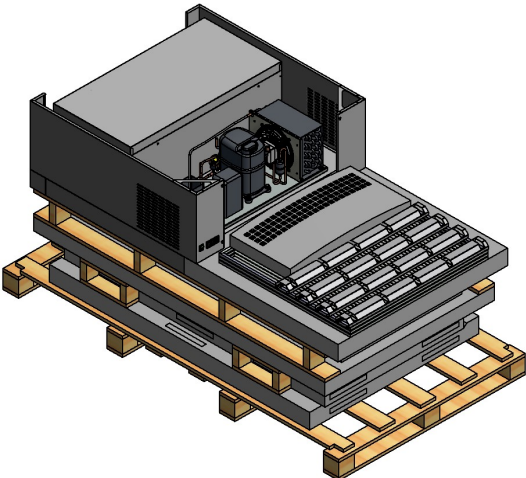
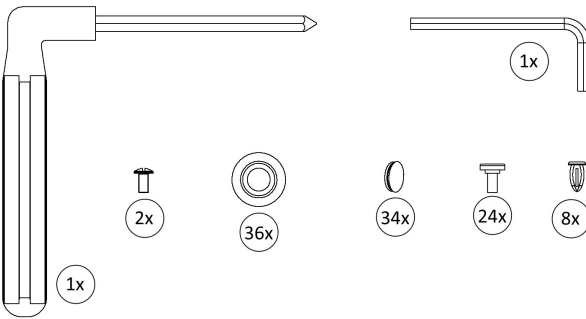
	<p>EN Two people handling/assembly required.</p> <p>FR Il est recommandé d'avoir deux personnes pour le maniement/montage.</p> <p>DE Empfehlenswert ist die Handhabung/Montage mit zwei Personen durchzuführen.</p> <p>NL Het is aanbevolen om de handling en montage door twee personen uit te voeren.</p>	<p>PT Recomenda-se manuseamento/montagem por duas pessoas</p> <p>IT E' necessario la presenza di due persone per la movimentazione e il montaggio.</p> <p>ES Se recomienda manipulación/ensambladura por dos personas.</p>
	<p>EN 1. Remove the cardboard packaging; 2. Remove the polystyrene.</p> <p>FR 1. Enlever l'emballage en carton; 2. Retirer le feuillard.</p> <p>DE 1. Die Verpackung abholen; 2. Entfernen des Befestigungsmaterials.</p> <p>NL 1. Verwijder de kartonnen verpakking; 2. Verwijder de bevestigingsbanden.</p>	<p>PT 1. Remover a embalagem de cartão; 2. Retirar as cintas.</p> <p>IT 1. Rimuovere la scatola di cartone; 2. Ritirare la reggia plastica.</p> <p>ES 1. Remover el embalaje de cartón; 2. Retirar el fleje.</p>
	<p>EN Materials / quantities delivered with the coldroom: Hex key 8 mm M5x10 Screws Alignment chips Hole covers Stud screws Grey screw caps Hex key 6 mm</p> <p>FR Matériaux / quantités livrés avec la chambre froide : Clé Allen 8 mm Vis M5x10 Jetons d'alignement Cache trous Boulons Caches gris Clé Allen 6 mm</p> <p>DE Materialien / Mengen, mit den Kühlzellen angelieferten: Innensechskantschlüssel 8 mm Schrauben M5x10 Ausrichtungsmarke Kunststoffstopfen Bolzen Graue Kunststoffstopfen Innensechskant 6 mm</p> <p>NL Materiaal / hoeveelheden geleverd met de cel: Zeskant steeksleutel 8mm schroeven M5x10 uitlijnschijven Stiftschroeven Kunststof afdekdopjes Imbusleutel 6mm</p>	<p>PT Materiais / quantidades entregues com a câmara: Chave hexagonal 8 mm Parafusos M5x10 Bolachas de alinhamento Tapa-furos Pernos Tacos cinza Chave hexagonal 6 mm</p> <p>IT Materiali consegnati con la cella frigorifera: Chiave a brugola 8 mm Viti M5x10 Gettoni di fissaggio Tappi fori Perni Cappucci grigi Chiave a brugola 6 mm</p> <p>ES Materiales / cantidades enviadas con la cámara frigorífica: Llave Allen 8 mm Tornillos M5x10 Piezas de alineación Tapones Pernos Tapones gris Llave Allen 6 mm</p>

2 CAMLOCK FASTENING | SERRAGE DES CROCHETS | ANSCHRAUBEN DER HACKEN | BEVESTIGEN VAN DE KLEMHAKEN | APERTO DOS FECHOS | AGGANCIAMENTO DEI FASTENERS | APRIETE DE LOS GANCHOS

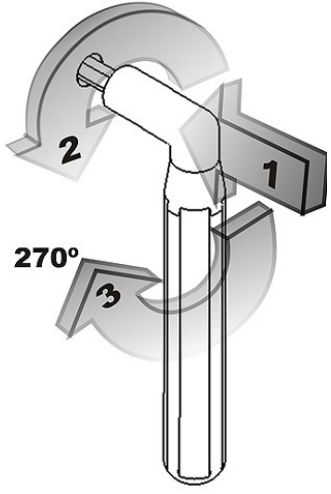
		<p>EN Camlock fastening from the inside of the cold room:</p> <ol style="list-style-type: none"> 1. Fit hex key (B) into the camlock until the plastic touches the panel; 2. Turn hex key (B) in a counterclockwise movement until it stops; 3. Turn hex key (B) in a 270° clockwise movement until it fastens. <p>FR Serrage des crochets par l'intérieur de la chambre :</p> <ol style="list-style-type: none"> 1. Encaisser la clé (B) dans le crochet jusqu'à ce que la butée s'accote au panneau ; 2. Tourner la clé (B) dans le sens contraire des aiguilles d'une montre jusqu'à l'arrêt; 3. Tourner la clé (B) dans le sens des aiguilles d'une montre 270° jusqu'à la fin de cours. <p>DE Befestigung der Haken im Inneren der Kühlzelle:</p> <ol style="list-style-type: none"> 1. Den Schlüssel (B) in den Verschluss bis zum Anschlag einstecken; 2. Den Schlüssel (B) entgegen den Uhrzeigersinn drehen, bis dieser zum Stehen kommt; 3. Den Schlüssel (B) im Uhrzeigersinn um 270° drehen, bis dieser fest angeschraubt ist. <p>NL Bevestiging van de klemhaken in de binnenkant van de cel:</p> <ol style="list-style-type: none"> 1. Plaats de sleutel (B) tot aan het handvat in de opening van het paneel ; 2. Draai de sleutel (B) in de tegenovergestelde richting van de wijzers van de klok tot het einde ; 3. Draai de sleutel (B) 270° in de richting van de wijzers van de klok. 	<p>PT Aperto dos fechos no interior da câmara:</p> <ol style="list-style-type: none"> 1. Encaixar a chave (B) no fecho até o batente encostar ao painel; 2. Rodar a chave (B) no sentido contrário aos ponteiros do relógio até parar; 3. Rodar a chave (B) no sentido dos ponteiros do relógio 270° até apertar. <p>IT Chiusura chiavi dall'interno della cella:</p> <ol style="list-style-type: none"> 1. Inserire la chiave (B) nel foro fino al contatto tra il distanziale e la parete. 2. Ruotare la chiave (B) in senso antiorario fino al blocco di questa. 3. Ruotare la chiave (B) in senso orario con apertura 270°. <p>ES Apretar los ganchos por el interior de la cámara frigorífica:</p> <ol style="list-style-type: none"> 1. Encajar la llave (B) en el gancho hasta que apoye en la chapa; 2. Girar la llave (B) en el sentido contrario de las agujas del reloj hasta que pare; 3. Girar la llave (B) en el sentido de las agujas del reloj 270° hasta que pare.
---	---	---	---

3 ASSEMBLY SEQUENCE | SÉQUENCE DE MONTAGE | MONTAGESEQUENZ | VOLGORDE VAN DE MONTAGE | SEQUÊNCIA DE MONTAGEM | SEQUENZA DI MONTAGGIO | SECUENCIA DE MONTAJE

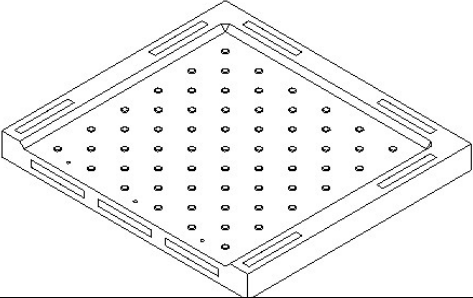
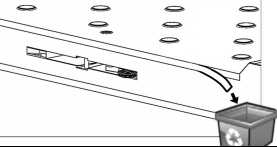
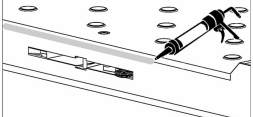
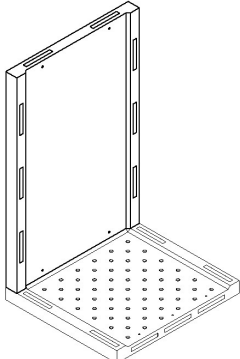
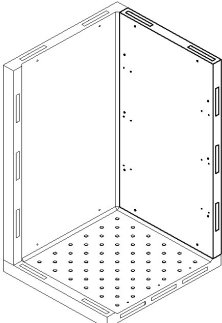
	<p>EN 1. Place the floor panel.</p> <p>FR 1. Placer le panneau du sol.</p> <p>DE 1. Den Boden in Position stellen.</p> <p>NL 1. Breng het paneel in positie.</p>	<p>PT 1. Posicionar o painel de solo.</p> <p>IT 1. Posizionare il pannello del pavimento.</p> <p>ES 1. Colocar el panel del piso.</p>
	<p>EN Remove the rubber tape.</p> <p>FR Retirer la bande en plastique.</p> <p>DE Entfernen Sie das Gummiband.</p> <p>NL Verwijder de plastic tape.</p>	<p>PT Retirar fita de plástico.</p> <p>IT Togliere il nastro di gomma.</p> <p>ES Retirar la banda de plástico.</p>
	<p>EN Put silicone.</p> <p>FR Mettre du silicone.</p> <p>DE Silikon legen.</p> <p>NL Breng silicone aan.</p>	<p>PT Colocar silicone.</p> <p>IT Mettere silicone.</p> <p>ES Poner silicona.</p>
	<p>EN 1. Fit the back panel; 2. Fasten the camlocks.</p> <p>FR 1. Emboiter le panneau arrière; 2. Serrer les crochets.</p> <p>DE 1. Die Rückwand einsetzen; 2. Die Haken anschrauben.</p> <p>NL 1. Plaats het achterpaneel in de gleuven; 2. Draai de koppelingen vast</p>	<p>PT 1. Encaixar o painel de fundo; 2. Apertar os fechos.</p> <p>IT 1. Fissare il pannello posteriore; 2. Fissare le chiusure.</p> <p>ES 1. Encajar el panel posterior; 2. Apretar los ganchos.</p>
	<p>EN 1. Fit the right side panel; 2. Fasten the camlocks.</p> <p>FR 1. Emboiter le panneau de droite; 2. Serrer les crochets.</p> <p>DE 1. Die Rechtswand einsetzen; 2. Die Haken anschrauben.</p> <p>NL 1. Plaats het rechter zijpaneel in de gleuven; 2. Draai de koppelingen vast.</p>	<p>PT 1. Encaixar o painel direito; 2. Apertar os fechos.</p> <p>IT 1. Fissare il pannello destro; 2. Fissare le chiusure.</p> <p>ES 1. Encajar el panel derecho; 2. Apretar los ganchos.</p>

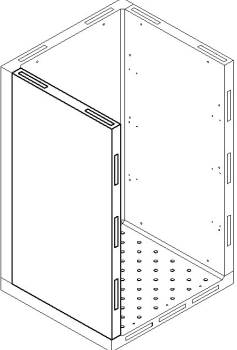
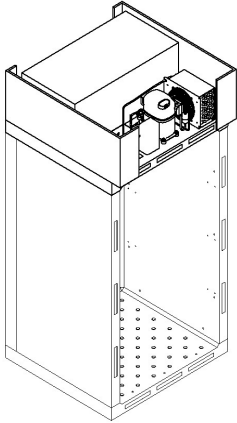
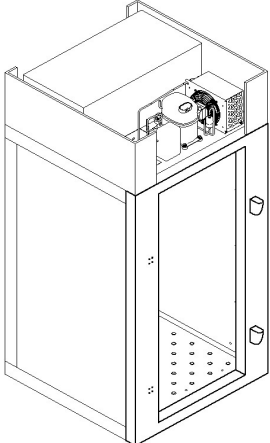
	<p>EN 1. Fit the left side panel; 2. Fasten the camlocks.</p> <p>FR 1. Emboiter le panneau de gauche; 2. Serrer les crochets.</p> <p>DE 1. Die Linkswand einsetzen; 2. Die Haken anschrauben.</p> <p>NL 1. Plaats het linker zijpaneel in de gleuven; 2. Draai de koppelingen vast.</p>	<p>PT 1. Encaixar o painel esquerdo; 2. Apertar os fechos.</p> <p>IT 1. Fissare il pannello sinistro; 2. Fissare le chiusure.</p> <p>ES 1. Encajar el panel izquierdo; 2. Apretar los ganchos.</p>
	<p>EN 1. Fit the cold unit panel; 2. Fasten the camlocks.</p> <p>FR 1. Emboiter le panneau du groupe; 2. Serrer les crochets.</p> <p>DE 1. Die Wand des Kühlungseinsatz einsetzen; 2. Die Haken anschrauben.</p> <p>NL 1. Plaats het koelunit paneel in de gleuven; 2. Draai de koppelingen vast.</p>	<p>PT 1. Encaixar o painel do grupo refrigerado; 2. Apertar os fechos.</p> <p>IT 1. Fissare il pannello del gruppo frigorifero; 2. Fissare le chiusure.</p> <p>ES 1. Encajar el panel del grupo frigorífico; 2. Apretar los ganchos.</p>
	<p>EN 1. Fit the door frame panel; 2. Fasten the camlocks.</p> <p>FR 1. Emboiter le panneau du cadre de la porte; 2. Serrer les crochets.</p> <p>DE 1. Die Wand des Türrahmens einsetzen; 2. Die Haken anschrauben.</p> <p>NL 1. Plaats het deurpaneel in de gleuven; 2. Draai de koppelingen vast.</p>	<p>PT 1. Encaixar o painel do aro da porta; 2. Apertar os fechos.</p> <p>IT 1. Fissare il pannello del telaio della porta; 2. Fissare le chiusure.</p> <p>ES 1. Encajar el panel del marco de la puerta; 2. Apretar los ganchos.</p>

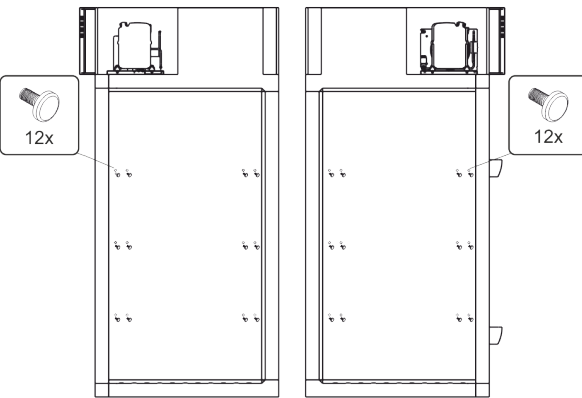
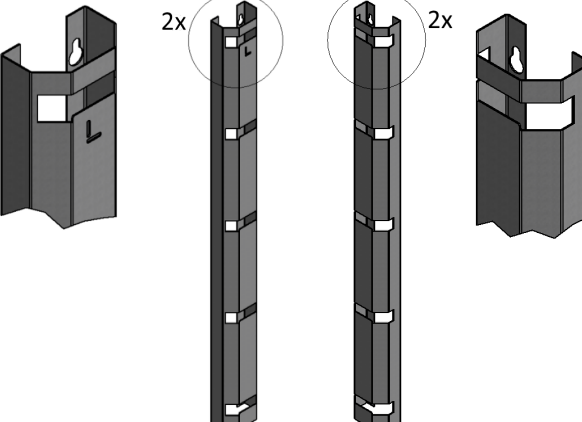
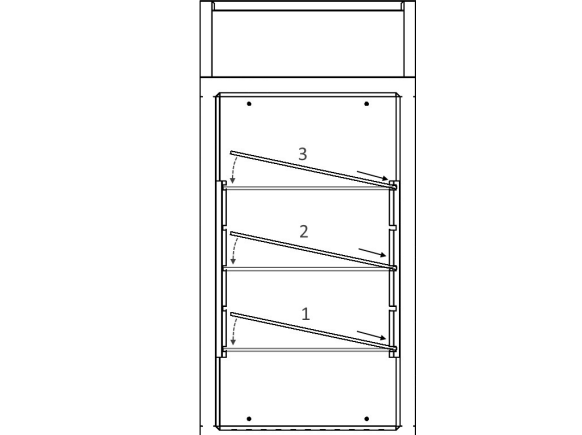
	<p>EN Insert stud screws (24x) to fix the grid supports.</p> <p>FR Placer les boulons (24x) pour la fixation des supports des grilles.</p> <p>DE Bringen Sie die Bolzen an, um die Halterung den Roste zu befestigen.</p> <p>NL Breng de stiftschroeven(24x) aan om de roostergeleiders te bevestigen</p>	<p>PT Colocar os pernos (24x) para a fixação dos montantes.</p> <p>IT Collocare i perni (24x) per fissare i montante.</p> <p>ES Colocar los pernos (24x) para fijar los montantes.</p>
	<p>EN <u>NOTE:</u> There are two different sets of supports. Place both the L-marked supports on the left hand side, and the other pair of supports on the right hand side.</p> <p>FR <u>REMARQUE:</u> Il y a deux paires de supports différents. Placer les deux supports marqués «L» à gauche, et l'autre paire de supports à droite.</p> <p>DE <u>HINWEIS:</u> Es gibt zwei verschiedene Arten von Trägern. Zeigen sowohl die Träger mit «L» auf der linken Seite, und das andere Paar von Trägern auf der rechten Seite.</p> <p>NL <u>LET OP!</u> Er zijn twee verschillende sets geleiders. Plaats beide met L gemerkte geleiders aan de linkerzijde, en de andere aan de rechterzijde</p>	<p>PT <u>NOTA:</u> Há dois tipos de suportes diferentes. Colocar os suportes marcados «L» no lado esquerdo, e o outro par de suportes no lado direito.</p> <p>IT <u>NOTA:</u> Ci sono due diversi tipi di supporti. Posizionare entrambi i supporti marcati «L» sul lato sinistro, e l'altra coppia di supporti sul lato destro.</p> <p>ES <u>NOTA:</u> Hay dos conjuntos diferentes de soportes. Colocar ambos los soportes marcados "L" en el lado izquierdo, y el otro par de soportes en el lado derecho.</p>
	<p>EN Put in place the shelves from bottom to top. Firstly, slide it in on the right hand side, and then insert it on the left hand side.</p> <p>FR Mettre en place les étagères du bas vers le haut. Tout d'abord, faites-les glisser sur le côté droit, puis insérez-les sur le côté gauche.</p> <p>DE Legen Sie die Regalen von unten nach oben. Erstens, schieben Sie sie in auf der rechten Seite, und legen Sie es auf der linken Seite.</p> <p>NL Plaats de roosters van onder naar boven, schuif eerst de rechterzijde op zijn plaats en daarna de linkerzijde</p>	<p>PT Colocar as prateleiras de baixo para cima. Primeiro encaixe-as do lado direito, depois insira-as do lado esquerdo.</p> <p>IT Mettere ripiani uno alla volta dal basso verso l'alto. Per posizionarli, inserirli prima sul lato destro e successivamente sul lato sinistro.</p> <p>ES Colocar las rejillas comenzando desde la más baja hasta la más alta. Deslizarlas primero hacia el lado derecho y luego encajarlas en el lado izquierdo.</p>

	EN Place the door (PM).	PT Colocar a porta (PM).
	FR Placer la porte (PM).	IT Fissare la porta (PM).
	DE Die Tür (PM) anbringen.	ES Colocar la puerta (PM).
	NL Breng de deur (PM) aan.	
	EN Position the frontal air vent.	PT Aplicar a grelha frontal de ventilação
	FR Appliquer la grille de ventilation avant.	IT Applicare la griglia di ventilazione anteriore.
	DE Wenden Sie die vorderen Lüftungsgitter .	ES Aplicar la rejilla de ventilación delantera.
	NL Monteer het ventilatierooster	

4 DOOR REVERSIBILITY AND ADJUSTMENTS | RÉVERSIBILITÉ DE LA PORTE ET RÉGLAGES | UMKEHRBARE TÜR UND TÜREINSTELLUNG | OMKEERBAARHEID VAN DE DEUR EN AFSTELLING | REVERSIBILIDADE DA PORTA E AFINAÇÕES | REVERSIBILITÀ DELLA PORTA ED AFFINAZIONI | REVERSIBILIDAD DE LA PUERTA Y REGLAJES

4.1 Door reversibility | Réversibilité de La Porte | Umkehrbare Tür | Omkeerbaarheid van de deur | Reversibilidade da porta | Reversibilità della porta | Reversibilidad de la puerta

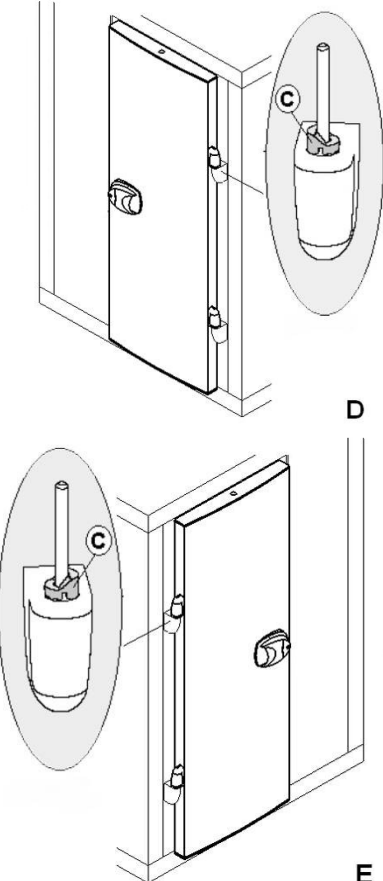
 <p>The image contains two technical diagrams, D and E, illustrating door hinge and lock sleeve configurations. Diagram D shows a door with a handle on the left and a lock sleeve (C) oriented vertically. Diagram E shows a door with a handle on the right and a lock sleeve (C) oriented horizontally. Both diagrams include circular callouts showing a close-up of the sleeve (C) and its orientation relative to the door's opening direction.</p>	<p>EN The door is easily reversible. Right door opening from factory settings. To invert the opening direction it is necessary to change the position and placement of the hinges and fit the lock stop at the opposite side.</p> <ul style="list-style-type: none"> ▪ The sleeve (C) must be oriented according to fig. D, when the door opens to the right. ▪ The sleeve (C) must be oriented according to fig. E, when the door opens to the left. <p>FR La porte est facilement réversible. La configuration d'usine est d'ouverture à droite. Afin d'inverser le sens de l'ouverture il faudra changer la position et l'emplacement des charnières et placer la butée de la serrure dans le côté opposé.</p> <ul style="list-style-type: none"> ▪ La bague (C) doit être orientée selon la fig. D, lorsque la porte ouvre à droite. ▪ La bague (C) doit être orientée selon la fig. E, lorsque la porte ouvre à gauche. <p>DE Die Tür ist leicht umkehrbar. Die Konfiguration ab Werk ist mit der Öffnung nach rechts. Um den Sinn der Öffnung zu wechseln, muss man die Position und Lage der Scharniere ändern und den Anschlag des Schlosses an die entgegengesetzte Seite stellen.</p> <ul style="list-style-type: none"> ▪ Die Hülse (C) soll nach Abb. (D) ausgerichtet werden, wenn die Tür nach rechts öffnet. ▪ Die Hülse (C) soll nach Abb. (E) ausgerichtet werden, wenn die Tür nach links öffnet. <p>NL De draairichting van de deur kan op eenvoudige wijze veranderd worden. Volgens de standaard opstelling opent de deur naar rechts. Om de richting van het openen te wijzigen, volstaat het om de positie en de ligging van de scharnieren te wijzigen en het handvat van de deur aan de tegenovergestelde zijde te bevestigen.</p> <ul style="list-style-type: none"> ▪ Bij rechtsdraaiende deur moet de huls (C) georiënteerd worden als aangegeven bij figuur D. ▪ Bij linksdraaiende deur moet de huls (C) georiënteerd 	<p>PT A porta é facilmente reversível. A configuração de fábrica tem abertura para a direita. Para inverter o sentido basta alterar a posição e localização das dobradiças e colocar o batente do lado oposto.</p> <ul style="list-style-type: none"> ▪ O casquilho (C) deve ser orientado conforme fig. D, quando a porta abre para a direita. ▪ O casquilho (C) deve ser orientado conforme fig. E, quando a porta abre para a esquerda. <p>IT La porta è facilmente reversibile. Nella configurazione standard ha l'apertura verso destra. Per invertire il senso di apertura è sufficiente variare la posizione delle cerniere e collocare la battuta della nel lato opposto.</p> <ul style="list-style-type: none"> ▪ La boccola (C) deve essere orientata come fig.D quando la porta apre verso destra. ▪ La boccola (C) deve essere orientata come fig.E quando la porta apre verso sinistra. <p>ES La puerta es fácilmente reversible. La configuración de fábrica es de abertura a la derecha. Si se quiere invertir el sentido de la abertura habrá que cambiar la posición y la ubicación de las bisagras y colocar el tope de la cerradura en el lado opuesto.</p> <ul style="list-style-type: none"> ▪ El casquillo (C) debe ser orientado según fig. D, cuando la puerta abre a la derecha. ▪ El casquillo (C) debe ser orientado según fig. E, cuando la puerta abre a la izquierda.
---	---	--

4.2 Door lock adjustment | Réglage de la serrure de la porte | Einstellung des Türschlosses | Afstelling van het deurslot | Afição do fecho da porta | Affinazione della serratura della porta | Afino de la cerradura de la puerta

EN After the cold room assembling you must check if the door magnetic gasket (PL) is fixed. If not, proceed as follow.

FR Après avoir monté la chambre froide : Vérifier si le joint magnétique de la porte (PL) est ajusté. Dans le cas contraire, procéder en accord avec le schéma suivant.

DE Nach der Montage der Kühlzelle sollte überprüft werden, ob die magnetische Dichtung der Tür (PL) angepasst wird. Anderenfalls, in Übereinstimmung mit dem folgenden Schema verfahren.

NL Na het monteren van de cel moet: Gecontroleerd worden of de dichting van de deur (PL) aangepast is. Is dit niet geval, ga dan verder volgens onderstaande schets.

PT Depois de montar a câmara deve: Verificar se o vedante da porta (PL) está ajustado. Caso não esteja, proceder de acordo com esquema abaixo.

IT Dopo il montaggio della cella deve: Verificare se la guarnizione magnetica della porta (PL) sia allineata.

ES Después del ensamblaje de la cámara frigorífica: Hay que verificar si la junta magnética de la puerta (PL) está ajustada. En el caso contrario, proceder de acuerdo con esquema siguiente.

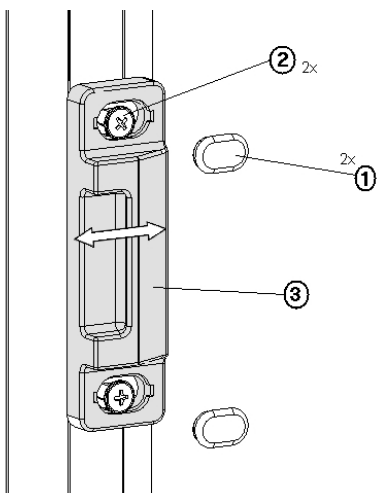
	<p>EN After assembling the cold room, check if the door magnetic gasket (PL) is fixed. To adjust the door lock :</p> <ul style="list-style-type: none"> ▪ Remove both covers (1); ▪ Slightly unfasten both screws(2); ▪ Adjust part (3), in the desired direction; ▪ Refasten both screws(2); ▪ Reinsert both covers (1). 	<p>PT Depois de montar a câmara, verificar se o vedante magnético da porta (PL) está ajustado. Para afinar o fecho da porta:</p> <ul style="list-style-type: none"> ▪ Retirar ambas as tampas (1); ▪ Desapertar ligeiramente ambos os parafusos (2); ▪ Ajustar a peça (3), no sentido pretendido; ▪ Reapertar ambas os parafusos (2); ▪ Recolocar ambas as tampas (1).
	<p>FR Après le montage de la chambre froide il faut vérifier si le joint magnétique de la porte (PL) est ajusté. Pour régler la serrure de la porte:</p> <ul style="list-style-type: none"> ▪ Retirer les deux couvercles (1); ▪ Desserrer légèrement les deux vis (2); ▪ Ajuster la pièce (3), dans le sens prétendu; ▪ Resserer les deux vis (2); ▪ Replacer les deux couvercles (1). 	<p>IT Terminato il montaggio della cella verificare che la guarnizione magnetica della porta (PL) sia allineata. Per modificare la chiusura della porta:</p> <ul style="list-style-type: none"> ▪ Togliere i tappi (1); ▪ Svitare leggermente le viti (2); ▪ Spostare il supporto (3), nel senso voluto; ▪ Riavvitare le viti (2); ▪ Riposizionare i tappi (1).
	<p>DE Nach der Montage der Kühlzelle sollte überprüft werden, ob die magnetische Dichtung der Tür (PL) angepasst wird. Um das Schloss der Tür einzustellen:</p> <ul style="list-style-type: none"> ▪ Die Deckel herausnehmen(1); ▪ Die Schrauben leicht lockern (2); ▪ Das Stück (3) anpassen; ▪ Die Schrauben anziehen (2); ▪ Die Deckel wieder anbringen (1). 	<p>ES Después de la ensambladura de la cámara frigorífica hay que verificar si la junta magnética de la puerta (PL) está ajustada. Para ajustar la cerradura de la puerta:</p> <ul style="list-style-type: none"> ▪ Retirar las tapas (1); ▪ Desapretar ligeramente los dos tornillos (2); ▪ Ajustar la pieza(3), en el sentido pretendido; ▪ Apretar los dos tornillos (2); ▪ Reponer las tapas (1).
	<p>NL Controleer na het monteren van de koelcel of de magneetsluiting aangepast is. Om het deurslot af te stellen:</p> <ul style="list-style-type: none"> ▪ Verwijder de kapjes (1); ▪ Beide schroeven (2) ietsje losschroeven; ▪ Pas het onderdeel (3) in de gewenste zin aan; ▪ Beide schroeven (2) terug vastschroeven; ▪ Beide beschermkapjes (1) terug aanbrengen. 	

4.3 Door hinges adjustment | Réglage des charnières de la porte | Türscharnieren anzupassen | Afstelling van de deurscharnieren | Ajustação das dobradiças da porta | Modificare le cerniere della porta | Ajustar las bisagras de la puerta

	<p>EN To adjust the hinges in the <u>horizontal and vertical</u> direction:</p> <ul style="list-style-type: none"> ▪ Remove the covers (1); ▪ Slightly unfasten the screws (2); ▪ Adjust the door in the desired direction(3); ▪ Refasten the screws (2); ▪ Reinsert the covers (1). 	<p>PT Para afinar as dobradiças no sentido <u>horizontal e vertical</u>:</p> <ul style="list-style-type: none"> ▪ Retirar as tampas (1); ▪ Desapertar ligeiramente os parafusos (2); ▪ Ajustar a porta no sentido pretendido (3); ▪ Reapertar os parafusos (2); ▪ Recolocar as tampas (1).
	<p>FR Pour ajuster les charnières dans le sens <u>horizontal et vertical</u>:</p> <ul style="list-style-type: none"> ▪ Retirer les couvercles (1); ▪ Desserrer légèrement les vis (2); ▪ Ajuster la porte dans le sens prétendu (3); ▪ Resserrer les vis (2); ▪ Replacer les couvercles (1). 	<p>IT Per modificare la posizione delle cerniere nel senso <u>orizzontale e verticale</u>:</p> <ul style="list-style-type: none"> ▪ Togliere i tappi (1); ▪ Svitare leggermente le viti (2); ▪ Spostare la porta nel senso voluto (3); ▪ Riavvitare le viti (2); ▪ Riposizionare i tappi (1).
	<p>DE Um die Scharniere der im <u>waagrechten und vertikalen Sinn</u> anzupassen:</p> <ul style="list-style-type: none"> ▪ Die Deckel herausnehmen (1); ▪ Die Schrauben leicht lockern (2); ▪ Die Tür (3), anpassen; ▪ Die Schrauben anziehen (2); ▪ Die Deckel wieder anbringen (1). 	<p>ES Para ajustar las bisagras en el sentido <u>horizontal e vertical</u>:</p> <ul style="list-style-type: none"> ▪ Retirar las tapas (1); ▪ Desapretar ligeramente los tornillos (2); ▪ Ajustar la puerta en el sentido pretendido (3); ▪ Apretar los tornillos (2); ▪ Reponer las tapas (1).
	<p>NL Om de scharnieren in van de deur in <u>horizontale en verticale</u> richting af te stellen:</p> <ul style="list-style-type: none"> ▪ Verwijder de kapjes (1); ▪ De schroeven (2) ietsje losschroeven; ▪ Stel de deur (3) in de gewenste zin af; ▪ De schroeven (2) terug vastschroeven; ▪ De beschermkapjes (1) terug aanbrengen. 	

Finanzen / Service

28307 Bremen
Thalendorststraße 15
Tel.+49 421 48557-0
Fax+49 421 488650
bremen@nordcap.de

Vertrieb Ost

12681 Berlin
Wolfener Straße 32/34, Haus K
Tel.+49 30 936684-0
Fax+49 30 936684-44
berlin@nordcap.de

Vertrieb West

40699 Erkrath
Max-Planck-Straße 30
Tel.+49 211 540054-0
Fax+49 211 540054-54
erkrath@nordcap.de

Vertrieb Nord

21079 Hamburg
Großmoorbogen 5
Tel.+49 40 766183-0
Fax+49 40 770799
hamburg@nordcap.de

Vertrieb Süd

55218 Ingelheim
Hermann-Bopp-Straße 4
Tel.+49 6132 7101-0
Fax+49 6132 7101-20
ingelheim@nordcap.de

