

NordCap®

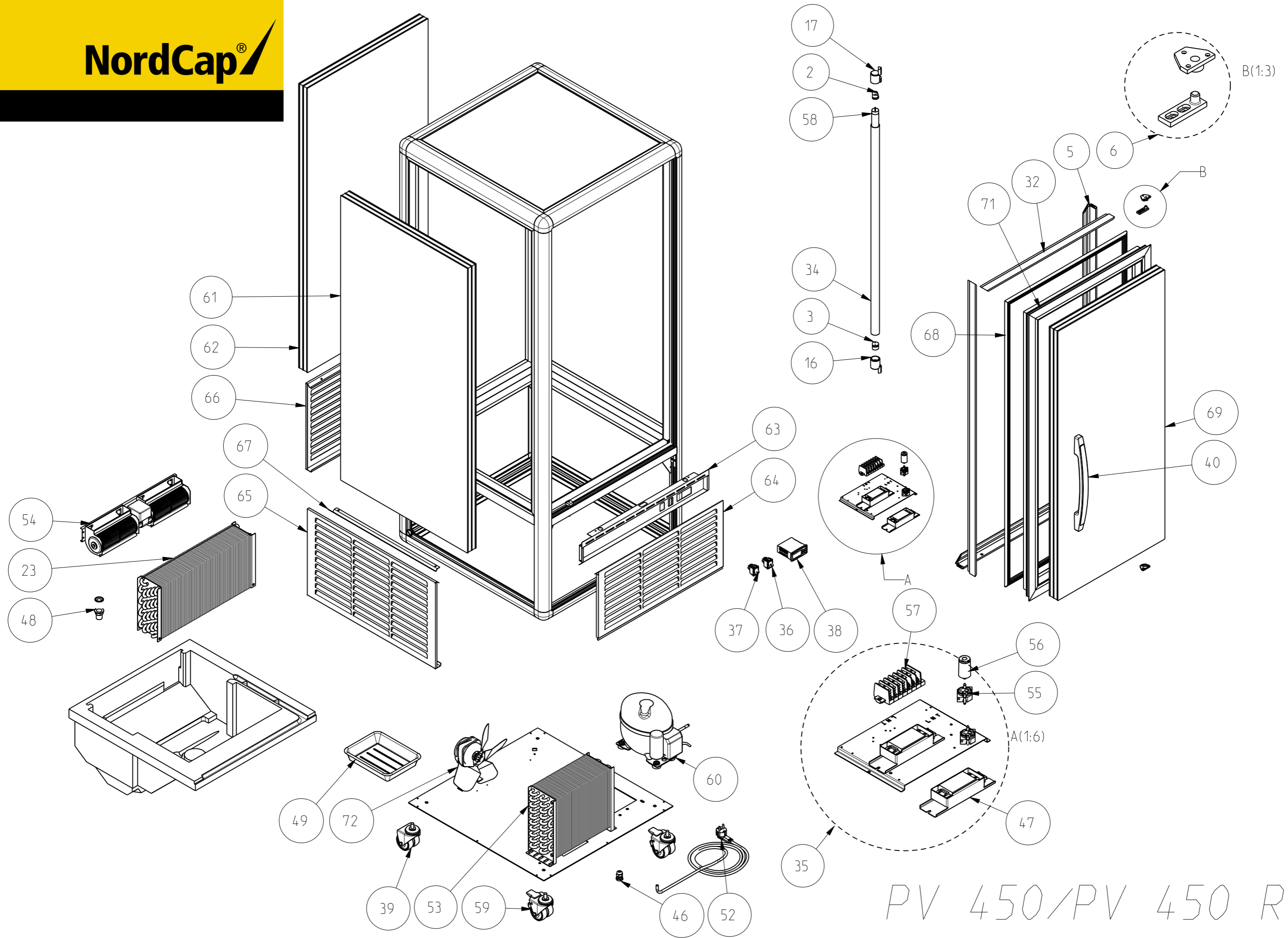

PV 450/PV 450 R

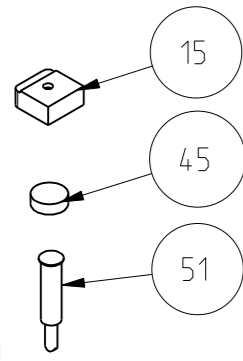

PV 450 R

D(1:3)

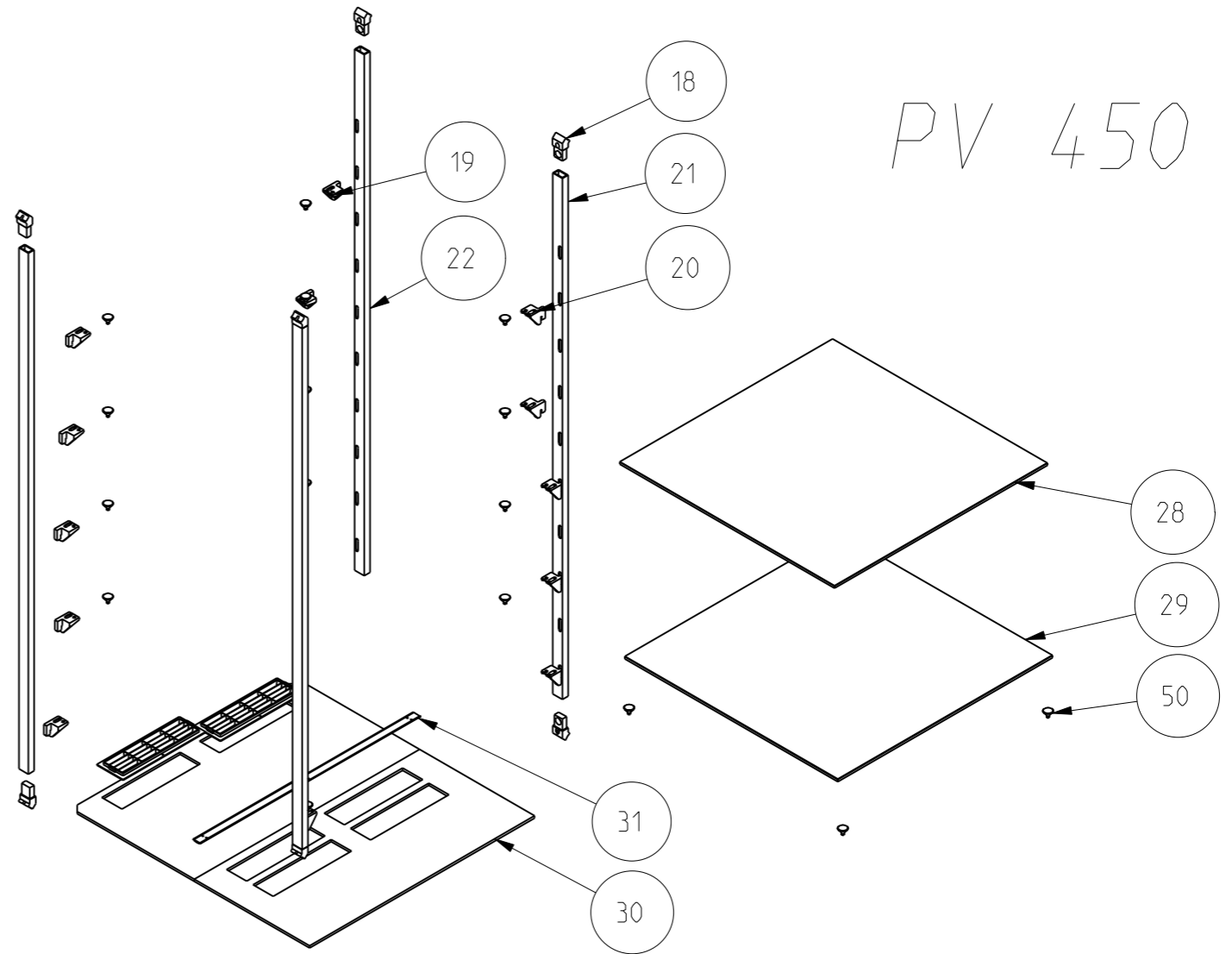
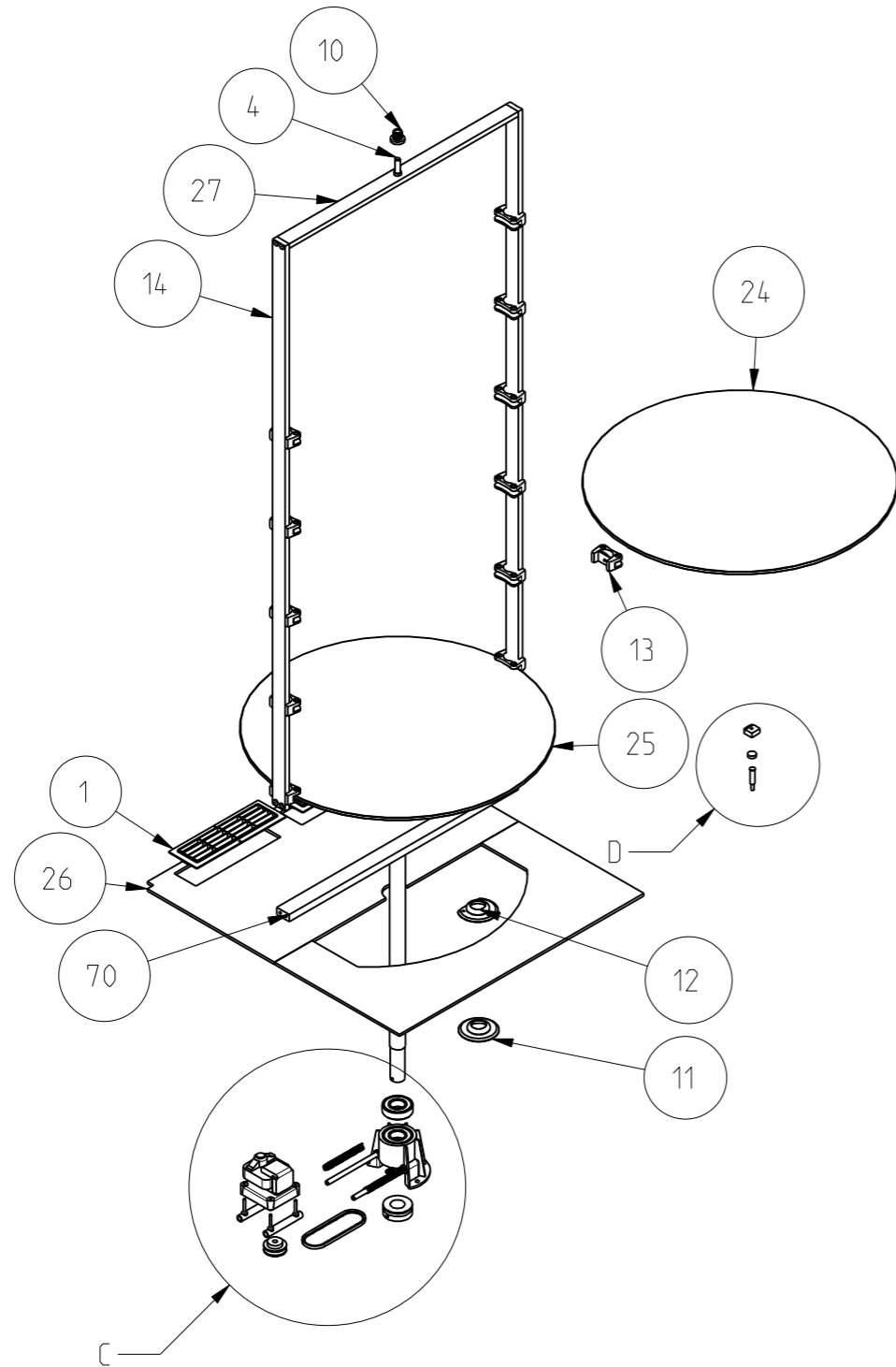

PV 450

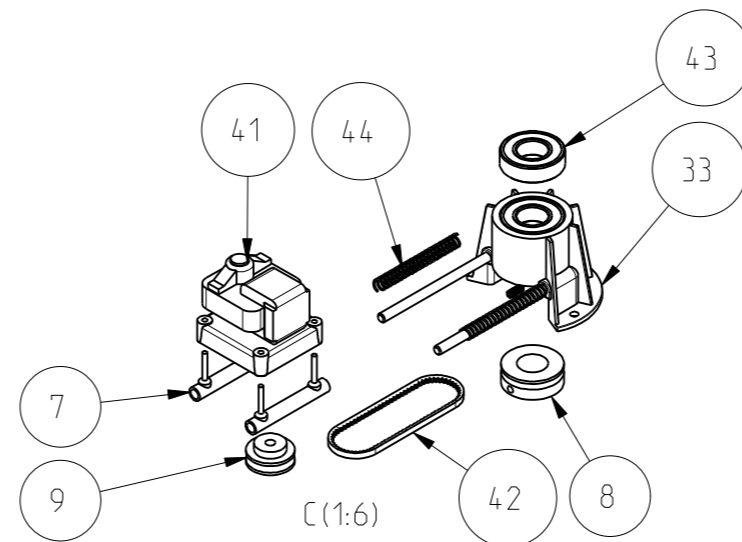

C(1:6)

PV 450 - PV 450 R

POS	DESCRIZIONE
1	Griglia in plastica / plastic grid / Kunststoff-Gitter / grille de plastique / rejilla de plástico
2	Frutto superiore / Upper contact holder / Oberer Kontakthalter / Porte-contact supérieur / Bornetera superior
3	Frutto inferiore / Lower contact holder / Unterer Kontakthalter / Porte-contact inférieur / Bornetera inferior
4	Perno / Pin / Zapfen / Axe / Eje
5	Cornice magnetica / Magnetic frame / Magnetische Rahmen / Cadre magnétique / Marco de cierre.
6	kit cerniere / Kit zippers / Werkzeuggreißverschlüsse / Kit charnières / Caja cremalleras
7	Supporto / Support / Lager / Support / Soporte.
8	Puleggia / Pulley / Flaschenzug / Poulie / Polea
9	Puleggia / Pulley / Flaschenzug / Poulie / Polea
10	Boccola superiore / Upper bush / Obere Buchse / Douille supérieur / Bullòn superior.
11	Guarnizione / Gasket / Dichtung / Joint / Burlete
12	Guarnizione / Gasket / Dichtung / Joint / Burlete
13	Morsetto / Clamp / Klemme / Étau / Mordaza.
14	Supporto verticale / Vertical support / Senkrechte Unterstützung / Support vertical / Respaldo vertical
15	Bloccaggio / Locking / Sperren / Verrouillage / Cierre
16	Copri-neon inferiore / Lower neon cover / Unterer Neondeckel / Couvre-néon inférieur / Cubre tubo inferior
17	Copri-neon superiore / Upper neon cover / Oberer Neondeckel / Couvre-néon supérieur / Cubre tubo superior
18	Supporto cremagliera / Rack support / Zahnstange des Trägers / Support de la crémaillère / Soporte de la cremallera
19	Mensola destra / Right bracket / Rechte Konsole / Console droite / Estribo derecho
20	Mensola sinistra / Left bracket / Linke Konsole / Console gauche / Estribo izquierdo
21	Cremagliera destra / Right rack / Rechte Zahnstange / Crémaillère droite / Cremallera derecha
22	Cremagliera sinistra / Left rack / Linke Zahnstange / Crémaillère gauche / Cremallera izquierda
23	Evaporatore / Evaporator / Verdampfer / Evaporateur / Evaporador
23	Evaporatore / Evaporator / Verdampfer / Evaporateur / Evaporador
24	Ripiano tondo in vetro / Round ledge in glass / Runder Sims in Glas / Étagère ronde en verre / Nivelo redondo en vidrio
25	Ripiano tondo a specchio / Ledge mirror circle / Simsspiegelkreis / Étagère ronde au miroir / Nivelo redondo a espejo
26	Piano interno R/ Internal shelf R/ Innenebene R/ Étagère intérieur R/ Plano interior R
27	Supporto orizzontale / Horizontal support / Waagerechte Unterstützung / Support horizontal / Soporte horizontal
28	Ripiano di vetro / Ledge of glass / Sims des Glases / Étagère de verre / Anaquel de vidrio
29	Ripiano a specchio / Mirror ledge / Spiegeln Sie Sims / Étagère au miroir / Nivelo a espejo
30	Piano interno G/ Internal shelf G/ Innenebene G/ Étagère intérieur G/ Plano interior G
31	Coprifilo / Wire cover / Drahtsdeckung / Couverture pour câbles / Tapajuntas.
32	Cornice orizzontale / Horizontal frame / Horizontaler Rahmen / Montant horizontal / Marco horizontal.
33	Boccola / Bush / Buchse / Douille / Bullòn.
34	Tubo / Pipe / Rohr / Tube / Tubo.
35	Pannello impianto elettrico / Wiring panel / Schalttafelplatte / Panneau installation électrique / Panel instalación eléctrica

POS	DESCRIZIONE
36	Interruttore bipolare freddo / Bipolar switch for cold / Zweipoliger Kälteschalter / Interrupteur bipolaire pour froid / Interruptor bipolar frío
37	Interruttore bipolare luce / Light bipolar switch / Zweipoliger Lichtschalter / Interrupteur bipolaire pour éclairage / Interruptor bipolar luz
38	Centralina elettronica / Electronic control / Elektronische Tafel / Contrôle électronique / Control electrónico
39	Ruota / Wheel / Rad / Roulette / Rueda
40	Maniglia / Handle / Griff / Poignée / Mango
41	Motoriduttore / Motoreducer / Getriebemotor / Motoreducteur / Motoreductor
42	Cinghia / Belt / Riemen / Courroie / Correa
43	Cuscinetto / Bearing / Lager / Roulment / Coijnete a boilla
44	Molla / Spring / Feder / Ressort / Resorte
45	Magnete porta / Door Magnet / Türmagnet / Porte Magnet / Puerta del imán
46	Pressacavo / Cable clip / Kabelhalter / Porte-câble / Sujeta-cables
47	Reattore / Ballast / Drosseln / Réacteur / Reactor
48	Piletta completa / Complete draining pipe / Kunststoffrohr mit Gegenmetter, komplett / Tuyau d'écoulement complet / Pileta completa
49	Bacinella / Basin / Becken / Bassin / Cuenca
50	Ventosa /Suction cup /Saugtasche /Ventouse /Pivote a ventosa
51	Microinterruttore / Microswitch / Mikroschalter / Micro-interrupteur / Microinterruptor
52	Cavo d'alimentazione / Supply cable / Speisekabel / Câble d'alimentation / Cable de alimentación
53	Condensatore / Condenser / Kondensator / Condenseur / Condensador
54	Ventilatore tangenziale / Tangential fan / Tangentiallüfter / Ventilateur tangentiel / Ventilador tangencial.
55	Portastarter / Starter holder / Starterhalter / Portarrancador / Porte-starter.
56	Starter / Starter / Starter / Arrancador / Starter
57	Morsettiera / Terminal block / Klemmbrett / Borne / Conector
58	Neon / Neon / Neon / Neon / Neón
59	Ruota con freno / Wheel with brake / Rou avec frein / Rader mit Bremse / Rueda con freno
60	Compressore / Compressor / Kompressoraggregat / Compresseur / Compresor
61	Vetro laterale / Side glass / Seitliches Glas / Verre Latéral / Cristal lateral.
62	Vetro posteriore / Rear glass / Hintere Glasscheibe / Vitre arrière / Vidrio trasero.
63	Pannello strumenti / Toolbox / Gremium für die Werkzeuge / Panneau des outils / Panel de los instrumentos
64	Griglia anteriore / Front grid / Vordergitter / Grille frontale / Rejilla anterior.
65	Griglia laterale / Side grid / Seiten Gitter / Grille latéral / Rejilla lateral.
66	Griglia posteriore / Rear grid / Hinterschutzgitter / Grille postérieure / Rejilla posterior.
67	Angolare fissaggio / Fastening angle / Anschlusswinkel / Cornière de fixation / Angular de fijación.
68	Guarnizione magnetica / Magnetic gasket / Magnetische Dichtung / Joint magnétique / Burlete
69	Vetro porta / Door glass / Türglas / Glace porte / Vidrio puerta.
70	Perno centrale / Central pivot / Zentraler Drehpunkt / Pivot central / Gozne central
71	Porta alluminio / Aluminum Door / bringt in Aluminium / Porte en aluminium / Puerta de aluminio
72	Ventilatore / Fan / Ventilator / Ventilateur / Ventilador

PV 450**PV 450 R**

1	0010201	0010201	
2	0054804	0054804	
3	0054805	0054805	
4	**	0080706	
5	0130215	0130215	ARGENTO
6	01302/19	01302/19	
7	**	0130702	
8	**	0130703	
9	**	0130704	
10	**	0130705	
11	**	0130706	
12	**	0130707	
13	**	0130724	ARGENTO
14	**	0130733	ARGENTO
15	**	0130742	
16	0134812	0134812	
17	0134813	0134813	
18	0150801	**	
19	0150802	**	
20	0150803	**	
21	0150811	**	
22	0150812	**	
23	0201901	0201901	
24	**	0270704	
25	**	0270705	
26	**	0270706	
27	**	0270716	ARGENTO
28	0270901	**	
29	0270902	**	
30	0290804	**	
31	0290806	**	ARGENTO
32	0350209	0350209	ARGENTO
33	**	01307/1	
34	01348/3	01348/3	
35	01548/1	01548/1	
36	A0302	A0302	
37	A0303	A0401	
38	A0736	A0736	
39	A0825	A0825	
40	A1603	A1603	ARGENTO
41	**	A2201	
42	**	A2301	
43	**	A2401	
44	**	A2501	
45	**	A2605	
46	A6303	A6303	
47	A6802	A6802	
48	A7001	A7001	

49	A7502	A7502	
50	A7901	**	
51	**	A2604	
52	A6501	A6501	
53	B4803	B4803	
54	B5105	B5105	
55	B5801	B5801	
56	B5901	B5901	
57	B6003	B6003	
58	B6303	B6303	
59	C2414	C2414	
60	E3864	E3864	
61	M720201	M720201	
62	M720202	M720202	
63	M720306	M720306	ARGENTO
64	M720307	M720307	ARGENTO
65	M720308	M720308	ARGENTO
66	M720309	M720309	ARGENTO
67	M720310	M720310	
68	M720401	M720401	
69	M720402	M720402	
70	**	M720701	
71	M7204/6	M7204/6	ARGENTO
72	X19004	X19004	